

# Superheterodyne Receiver

- Most popular type of a radio receiver so far.
- Used for AM/FM & TV broadcasting, cellular & satellite systems, radars, GPS etc.
- Main idea: downconvert RF signal to some fixed lower (intermediate) frequency, then amplify it and detect.

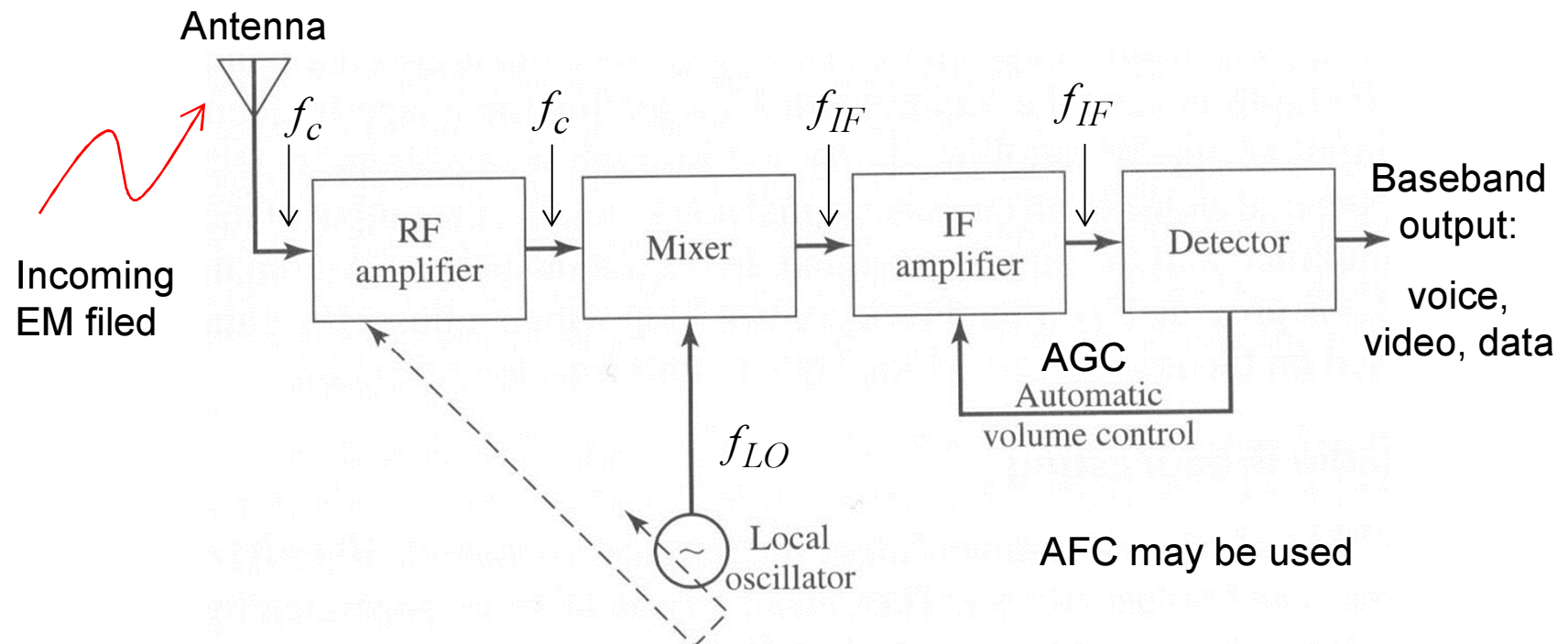

# Superheterodyne Receiver

- **RF amplifier:** amplifies a weak radio frequency (RF) signal coming out of the antenna. Rejects the image frequency. Bandwidth: much wider than the signal bandwidth.
- **Mixer:** together with the local oscillator downconverts the RF signal to the intermediate frequency (IF) frequency band.
- **IF amplifier:** amplifies the IF signal significantly (up to  $10^6$ ) and rejects adjacent channel signals and interference (frequency selectivity). Its bandwidth is the same as the signal bandwidth.
- **Detector (demodulator):** demodulates (recovers) the message signal.
- **AGC:** adjusts the IF amplifier gain according to the signal level (to keep the average signal amplitude almost constant)
- **Local oscillator:** allows tuning the receiver to a desired channel (frequency).

# Image Response

- Image response: overlaps with the desired signal & creates interference -> must be rejected
- Image frequency  $f_{image}$  : a “mirror image” of  $f_c$  w.r.t  $f_{LO}$

$$\left| f_{image} - f_c \right| = 2f_{IF}$$

# Intermediate Frequency and Image Response

- IF must be such that the image response is rejected by RF amplifier.

up-side conversion

$$f_{LO} = f_c + f_{IF}$$

down-side conversion

$$f_{LO} = f_c - f_{IF}$$

- Image frequency:

up-side conversion

$$\begin{aligned} f_{image} &= f_{LO} + f_{IF} = \\ &= f_c + 2f_{IF} \end{aligned}$$

down-side conversion

$$\begin{aligned} f_{image} &= f_{LO} - f_{IF} = \\ &= f_c - 2f_{IF} \end{aligned}$$

- Image rejection:  $\Delta f_{RF} < 2f_{IF}$

# Example: AM Broadcast Receiver

- Incoming RF signal:  $f_c = 850$  kHz      IF signal:  $f_{IF} = 455$  kHz
- Up-side conversion:  $f_{LO} = f_c + f_{IF} = 1305$  kHz
- Image frequency:  $f_{image} = f_{LO} + f_{IF} = f_c + 2f_{IF} = 1760$  kHz

Note: image rejection is due to RF amplifier only!  
IF must be high enough to reject the image response.

On the other hand, IF must be low enough to provide large gain and adjacent channel rejection.

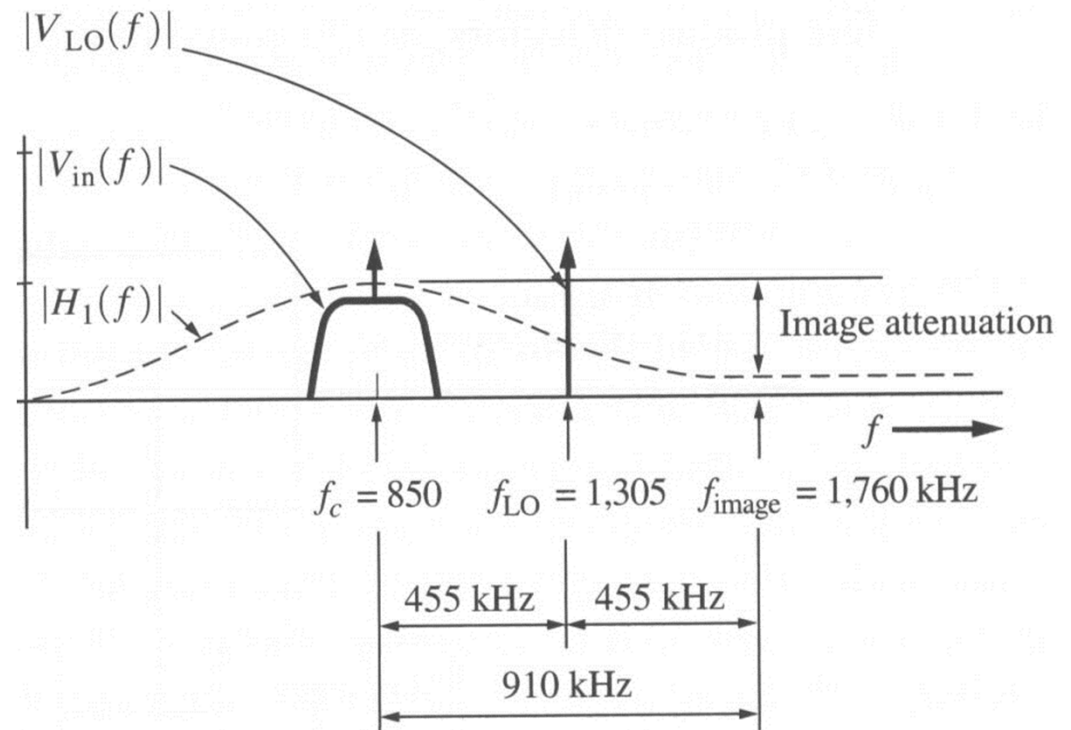

# Radio Transmitter

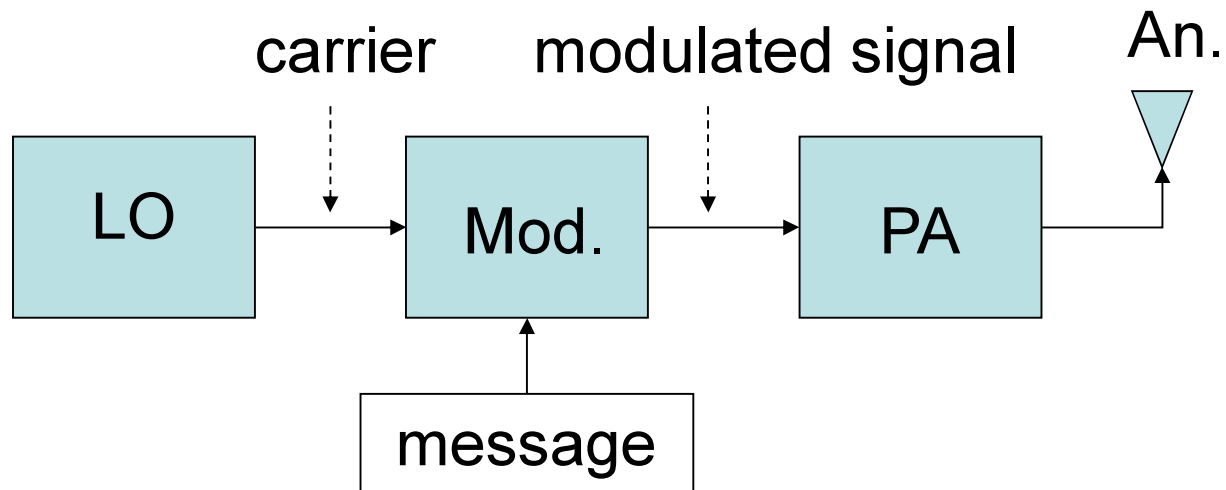

- Local oscillator (LO) – generates the carrier
- Modulator (Mod.) – modulates the carrier using the message signal
- Power amplifier (PA) – amplifies the modulated signal to required power level
- Antenna (An.) – radiates the modulated signal as an electromagnetic wave

# Radio Transmitter: Generalized Modulator

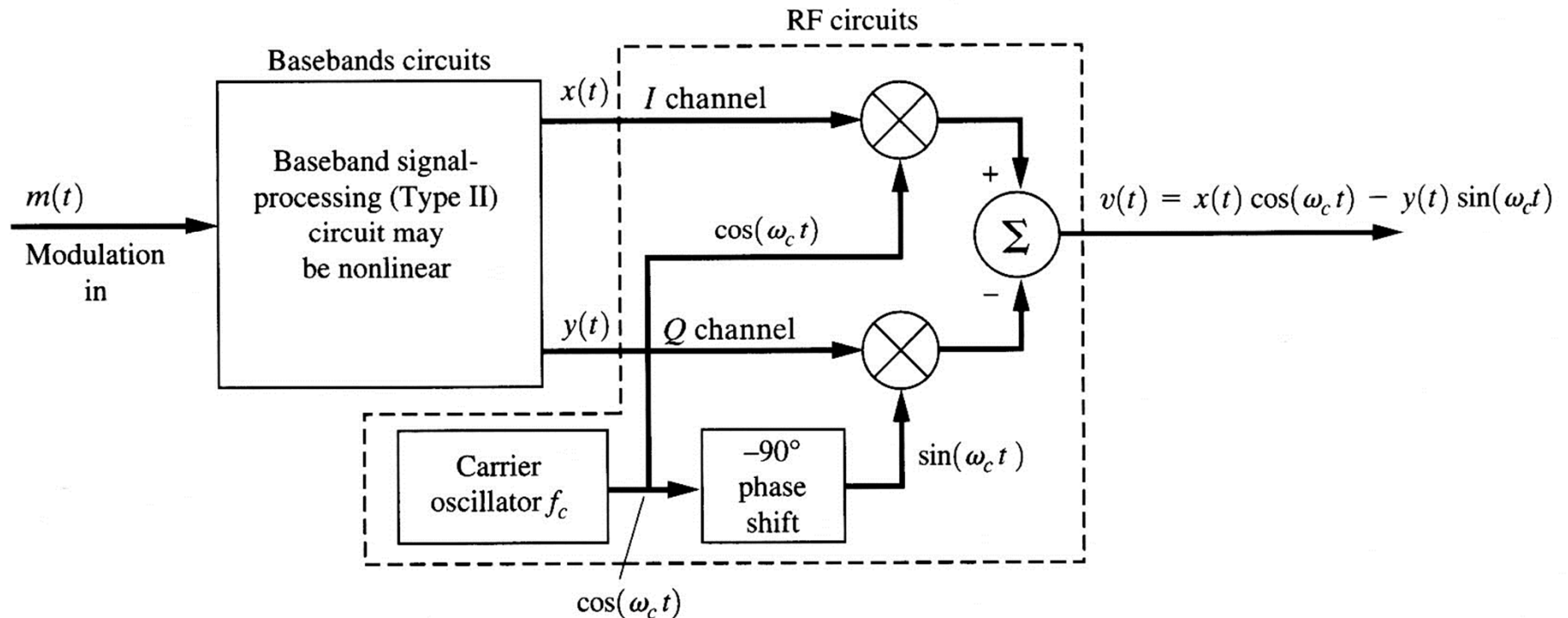

**Figure 4-28** Generalized transmitter using the quadrature generation technique.

L.W. Couch II, Digital and Analog Communication Systems, Prentice Hall, 2001.

# Radio Transmitter: Generalized Modulator

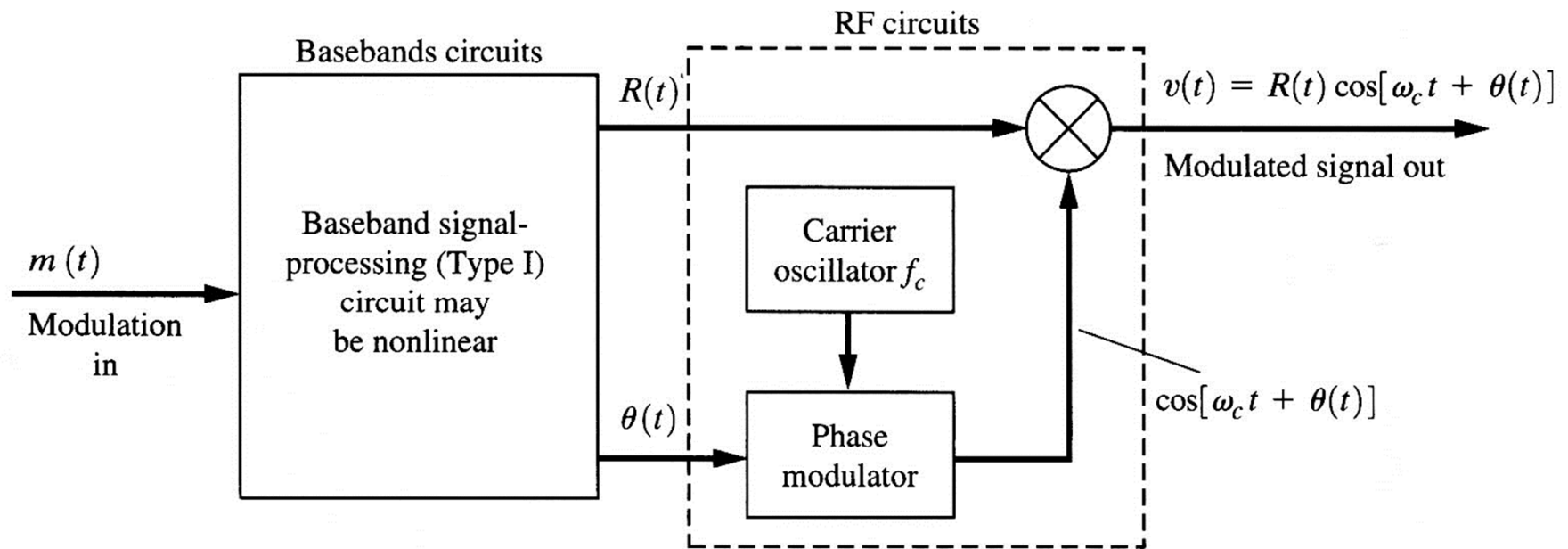

**Figure 4–27** Generalized transmitter using the AM–PM generation technique.

L.W. Couch II, Digital and Analog Communication Systems, Prentice Hall, 2001.



# Multiplexing

- Multiplexing: combining a number of message signals into a composite signal to transmit them simultaneously over a wideband channel.
- Two commonly-used types: time-division multiplexing (TDM) and frequency division multiplexing (FDM).
- TDM: transmit different message signals in different time slots (mostly digital).
- FDM: transmit different message signals in different frequency slots (bands) using different carrier frequencies.

# Frequency Division Multiplexing

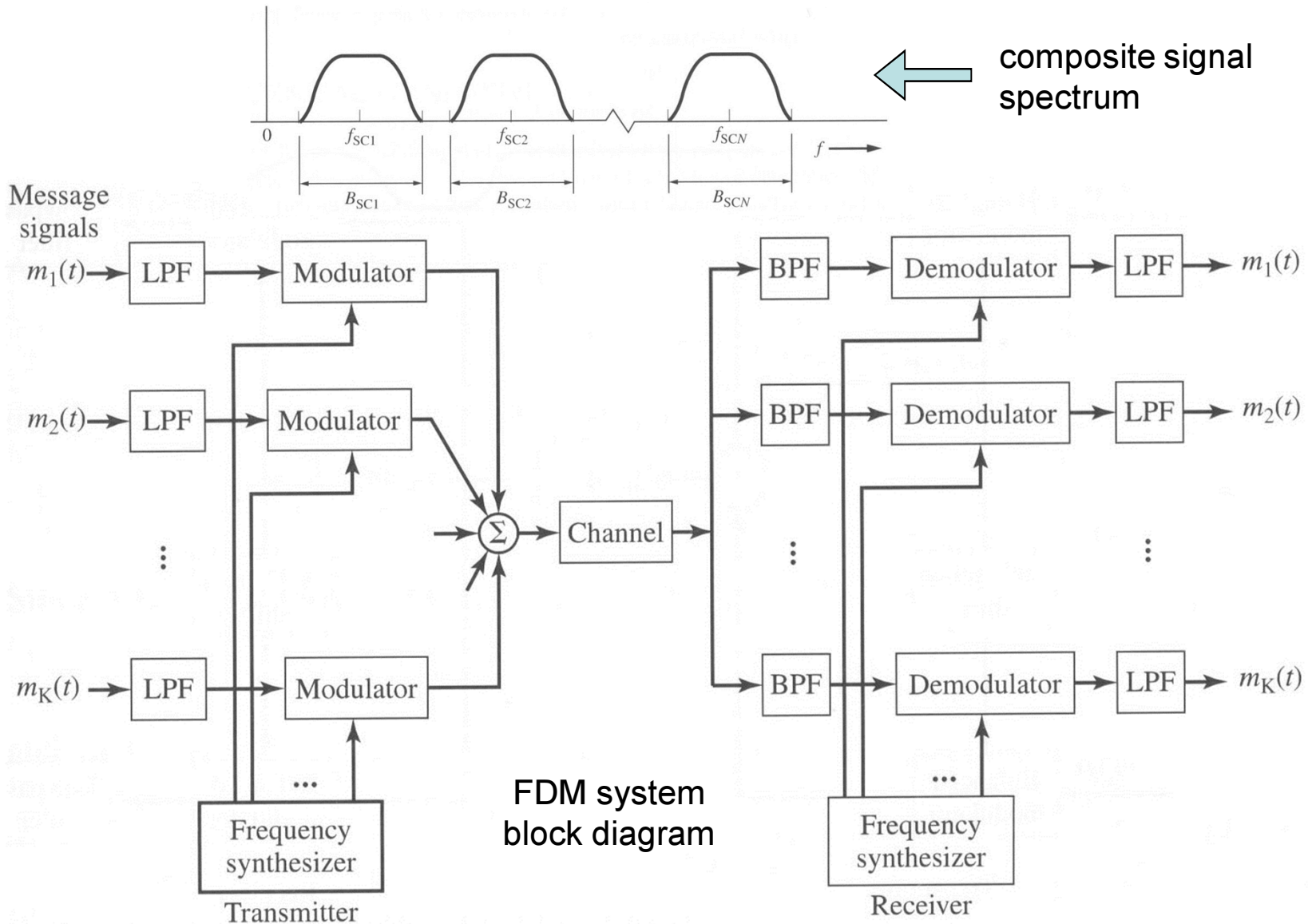

J.Proakis, M.Salehi, Communications Systems Engineering, Prentice Hall, 2002

# Time Division Multiplexing

- Similar to FDM -> the signals are separated in time (instead of frequency)

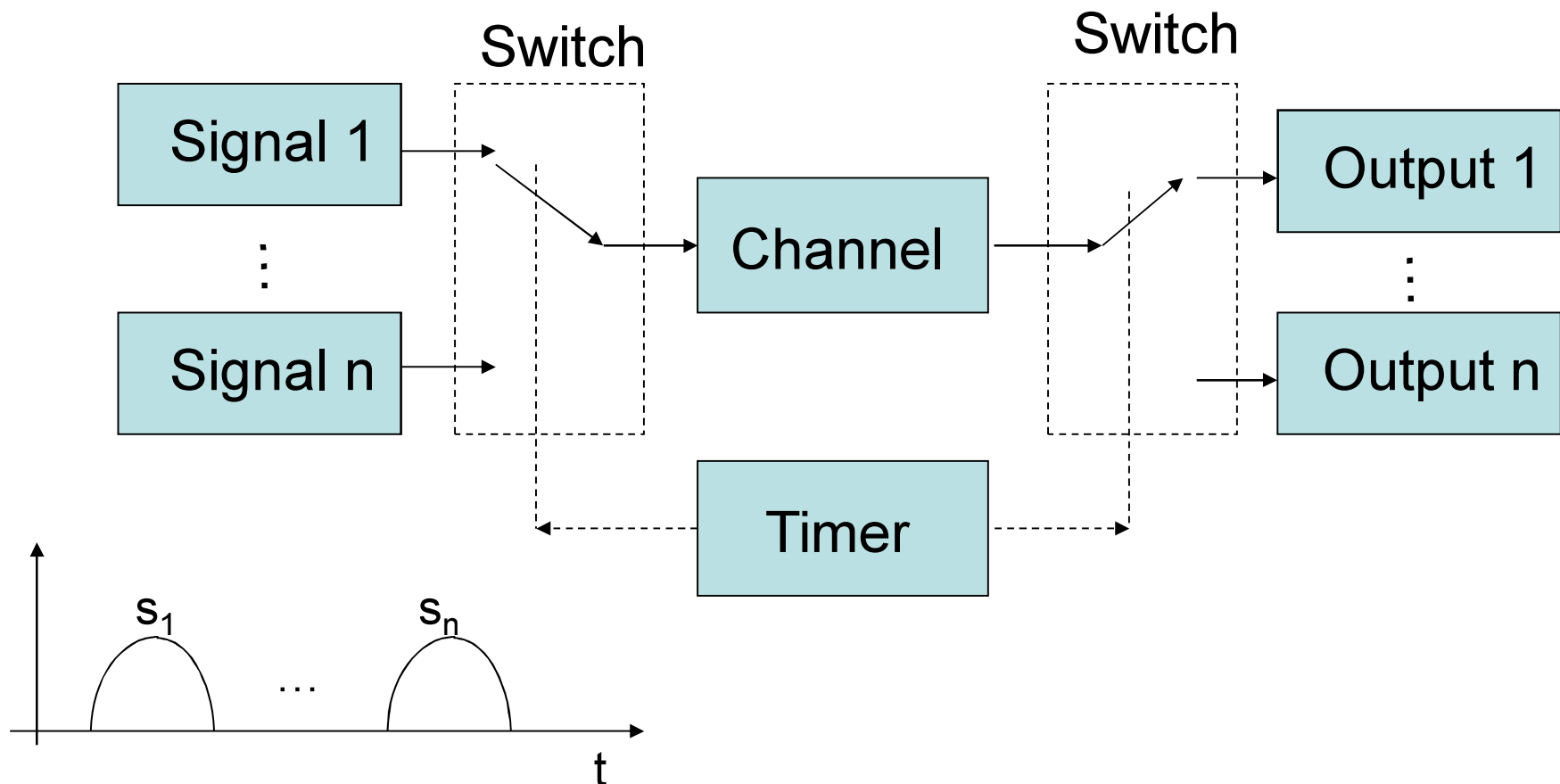

# Summary

- Superheterodyne receiver. Block diagram. Image response.
- Multiplexing. Frequency division multiplexing. System block diagram.
- **Homework**: Reading: Couch, 4.16, 4.17, 5.7, 5.8. Study carefully all the examples and make sure you understand them.