

# Quantum-Dash Mode-Locked Laser For Duplex Radio Over Fiber Links

Jianping Yao<sup>1</sup>, Long Huang<sup>1</sup>, Zhenguo Lu<sup>2</sup>, and Ke Wu<sup>3</sup>

1. School of Electrical Engineering and Computer Science, University of Ottawa
2. Electronics and Photonics Research Center, National Research Council Canada
3. Poly-Grames Research Center, École Polytechnique de Montréal

Université d'Ottawa | University of Ottawa



uOttawa

L'Université canadienne  
Canada's university

IPC 2023

Orlando, Florida, USA

Nov. 12-16, 2023

[www.uOttawa.ca](http://www.uOttawa.ca)



# Outline

---

- Introduction
- A duplex RoF link
  - Quantum-dash mode-locked laser
  - Duplex transmission experiment
  - MIMO transmission
  - Phase noise compensation
- Photonic integrated solution
- RoF links for integrated sensing and communications (ISAC)
- Conclusion

# Introduction

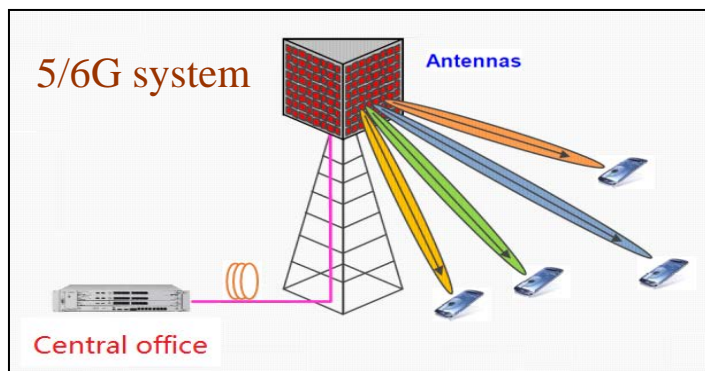
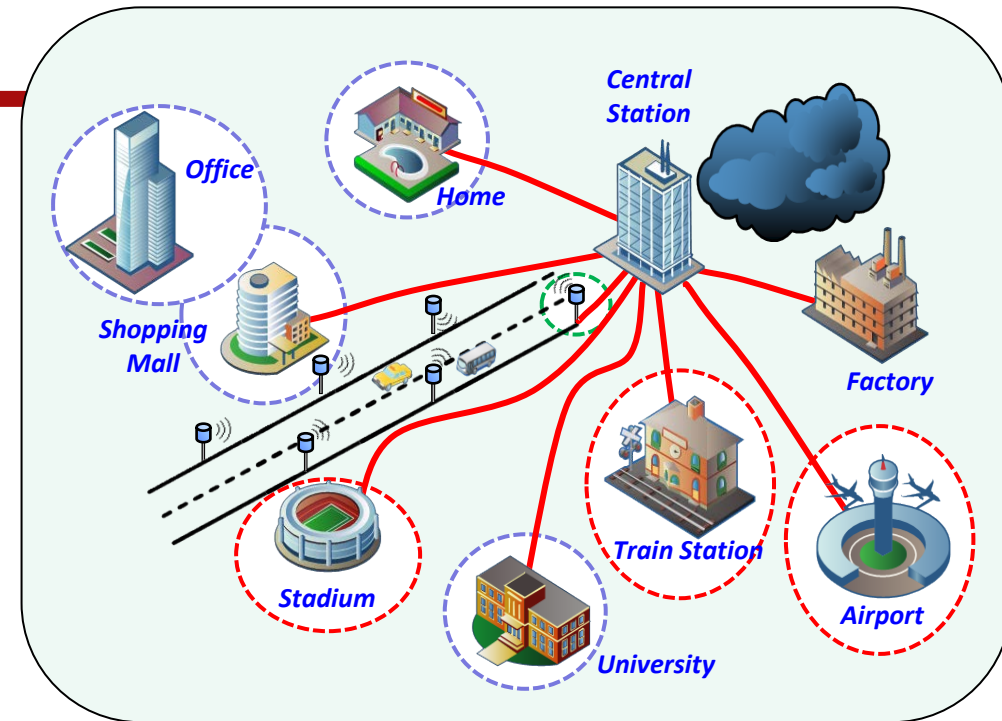
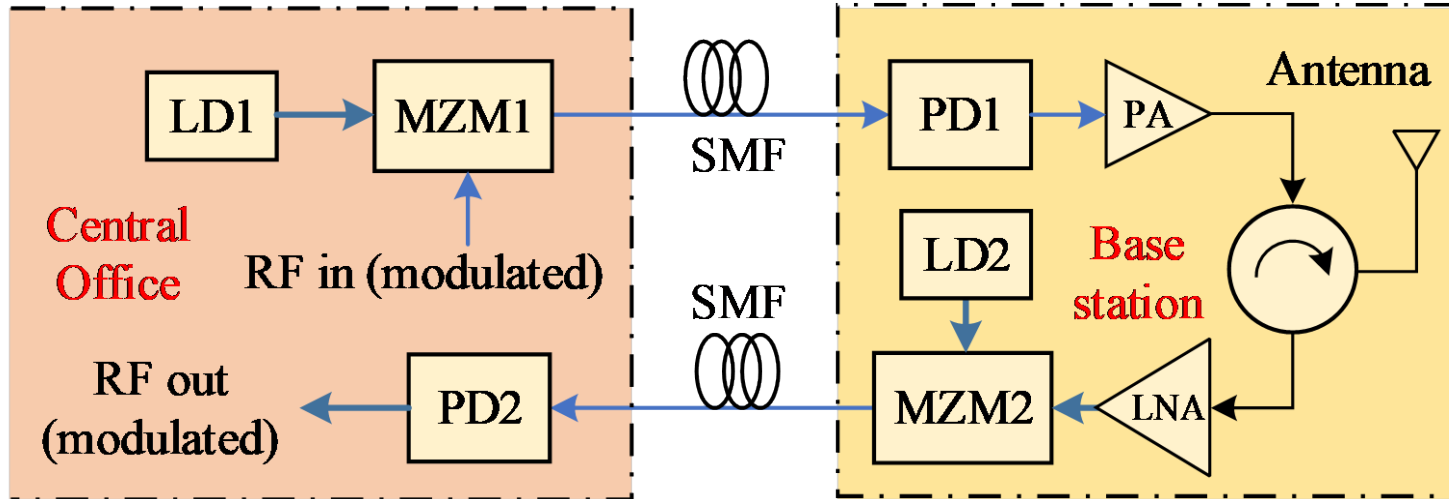

- **High speed and wideband signal transmission over fiber with ultra-low loss**
- **Simplified base station, all signal processing in central office**
- **For 5/6G applications**

# Outline

---

- Introduction
- **A duplex RoF link**
  - Quantum-dash mode-locked laser
  - Duplex transmission experiment
  - MIMO transmission
  - Phase noise compensation
- Photonic integrated solution
- RoF links for integrated sensing and communications (ISAC)
- Conclusion

# Architecture of a duplex RoF link

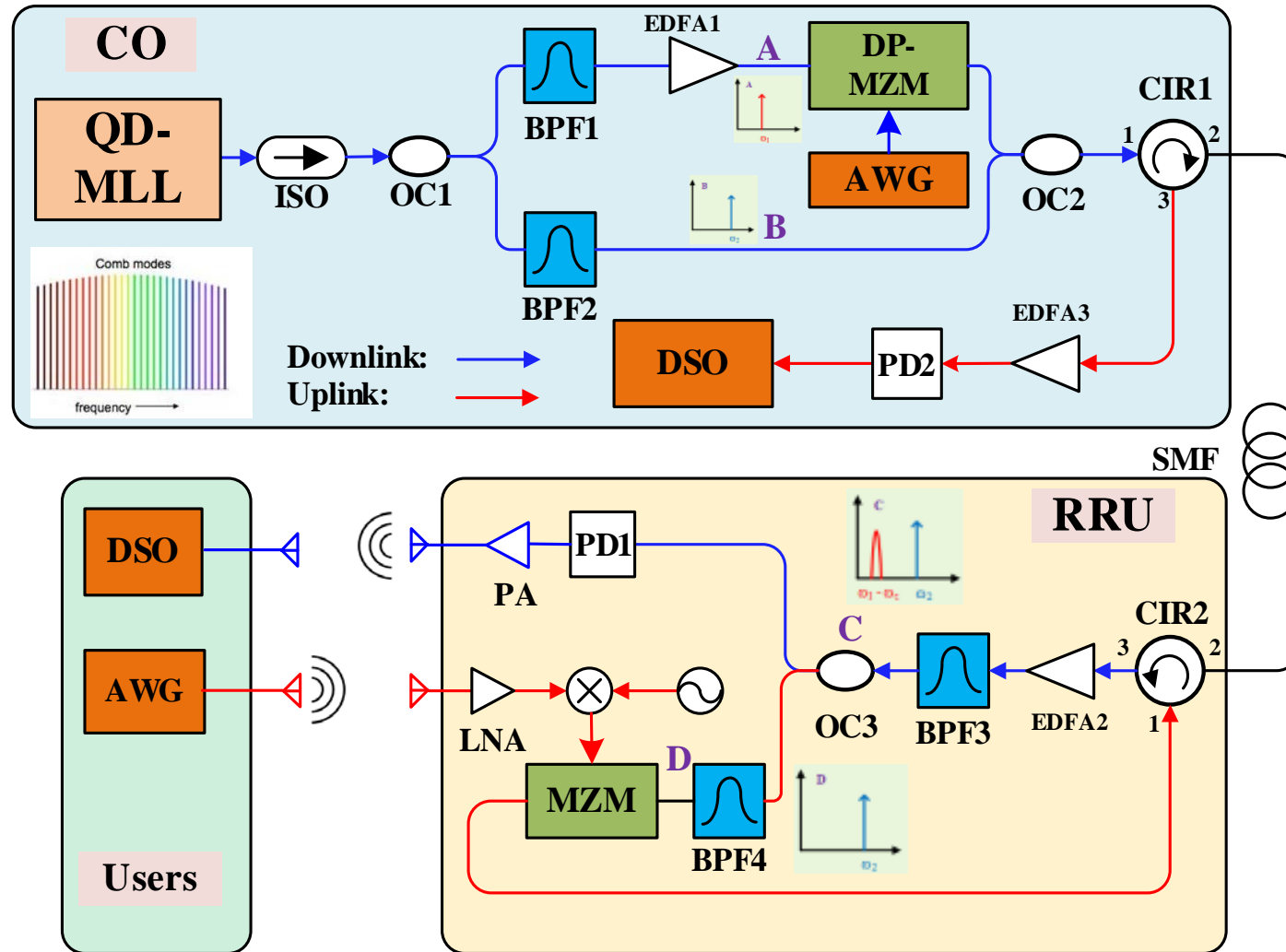
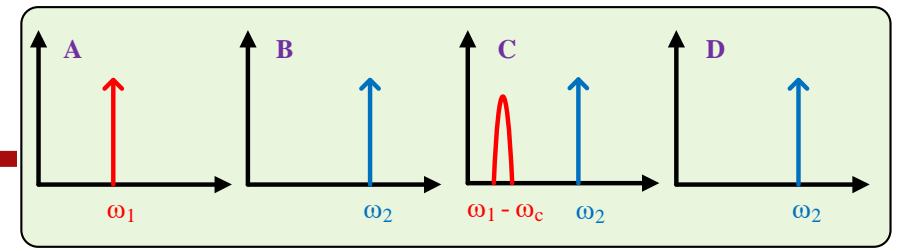

Downlink:

- Two comb lines are selected and filtered (Spacing: 0.2-nm/ 25.08 GHz (MMW)).
- One comb line is single sideband modulated by a 3-GHz 16-QAM vector signal at a DPMZM.
- A 25.08-GHz 16QAM vector signal is generated by beating the modulated comb line and an adjacent comb line.
- The MMW signal is radiated and received using a pair of horn antenna.

Uplink:

- The unmodulated comb line is reused as an optical carrier for uplink.
- A 28 GHz 16QAM vector signal is transmitted and received using a pair of horn antenna and is downconverter to 3 GHz and then modulates the reused comb line.
- Signals from two links can transmit through one fiber link by using two circulators.

# QD mode-locked laser

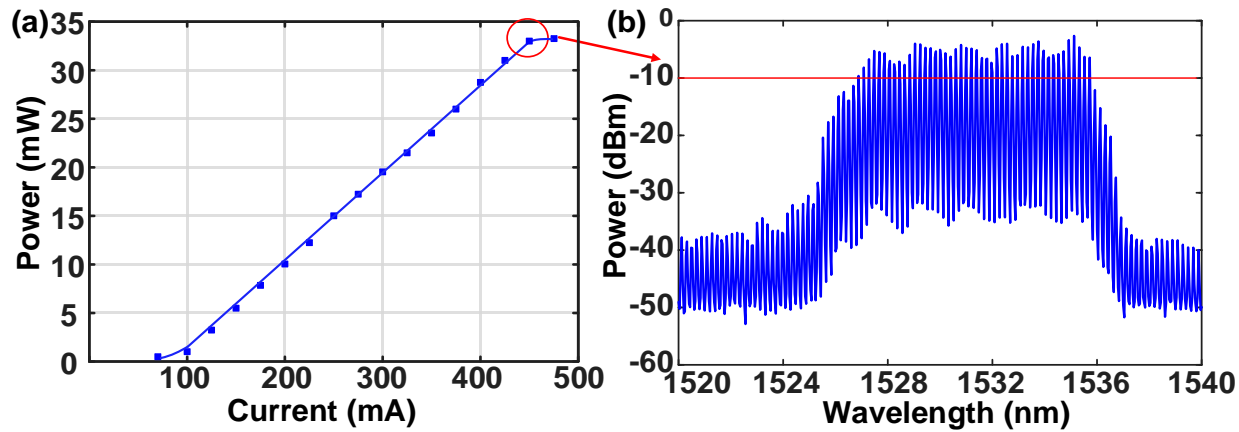
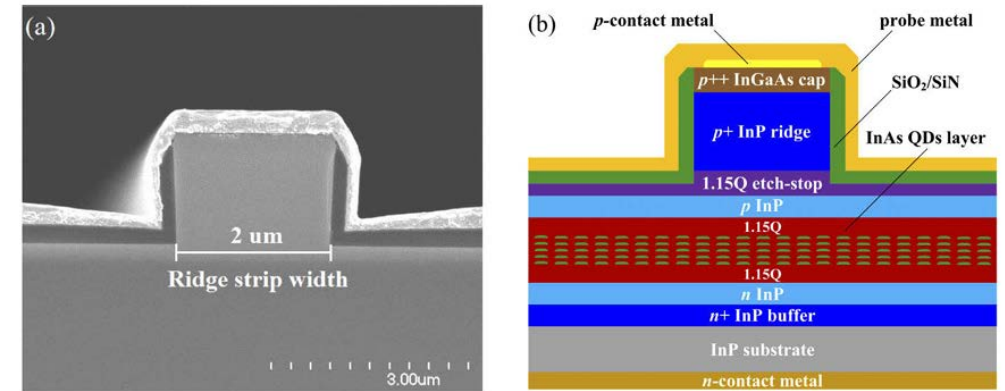

(a) Output power versus the injection current of the QD-MLL; (b) optical spectrum of the QD-MLL (45 comb lines) when the injection current is 430 mA. The spacing between two adjacent comb lines is **25.08 GHz**.

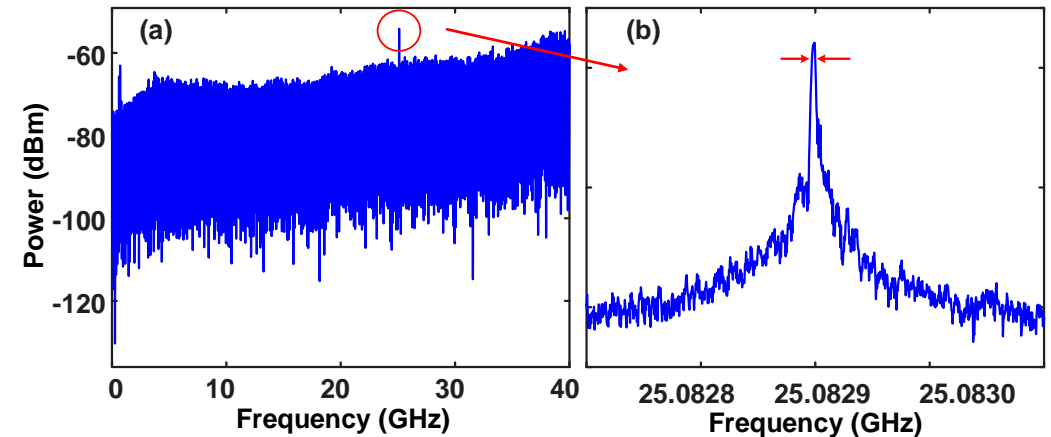

The electrical spectrum of a heterodyning beat signal at **25.08 GHz** and its zoom-in view.

# QD mode-locked laser

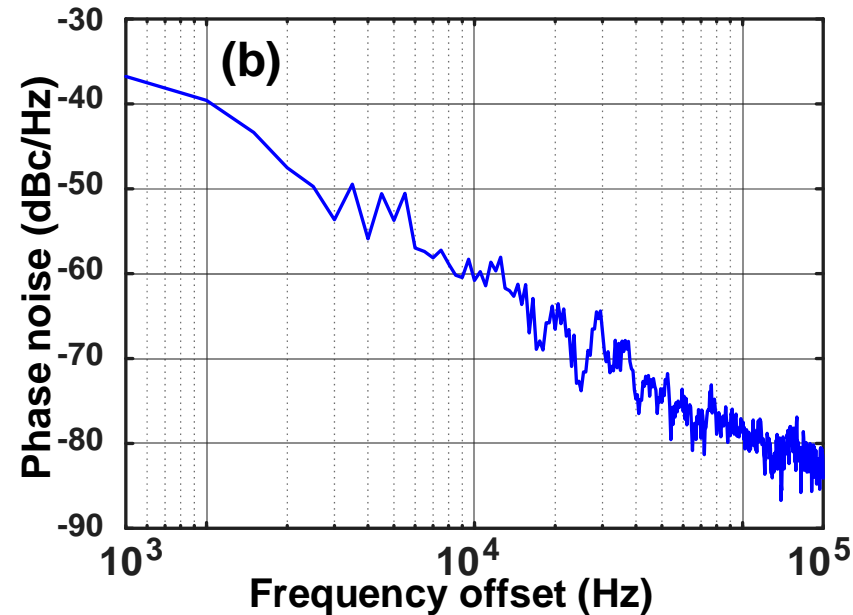
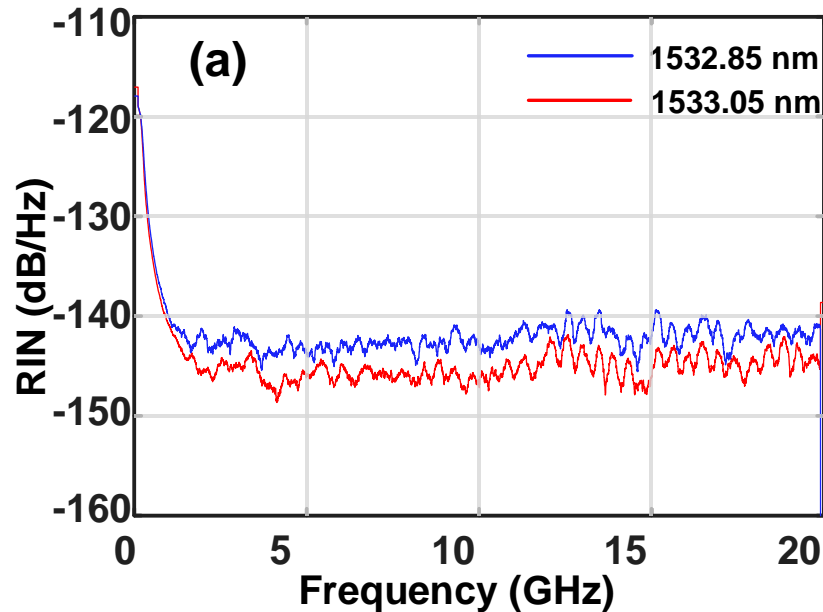

The phase noise consists of two parts:

- 1) the phase noise due to the time delay between the two comb lines and
- 2) the differential phase noise due to passive mode locking jitter.

(a) RIN spectra of the two selected adjacent comb lines with wavelengths at 1532.85 nm and 1533.05 nm. (b) The single-sideband phase noise of the microwave beat signal.



# Duplex RoF link experiment - 10 km SMF in the duplex mode

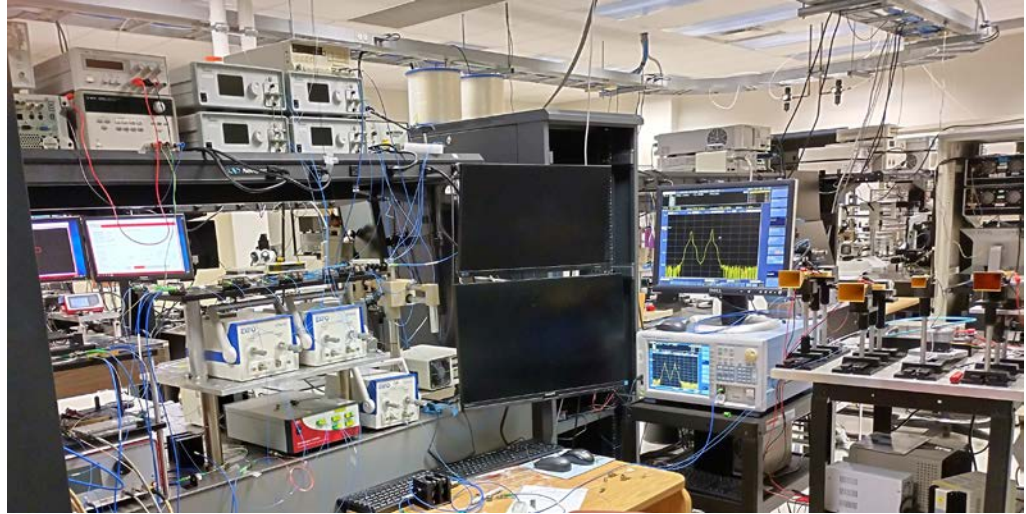
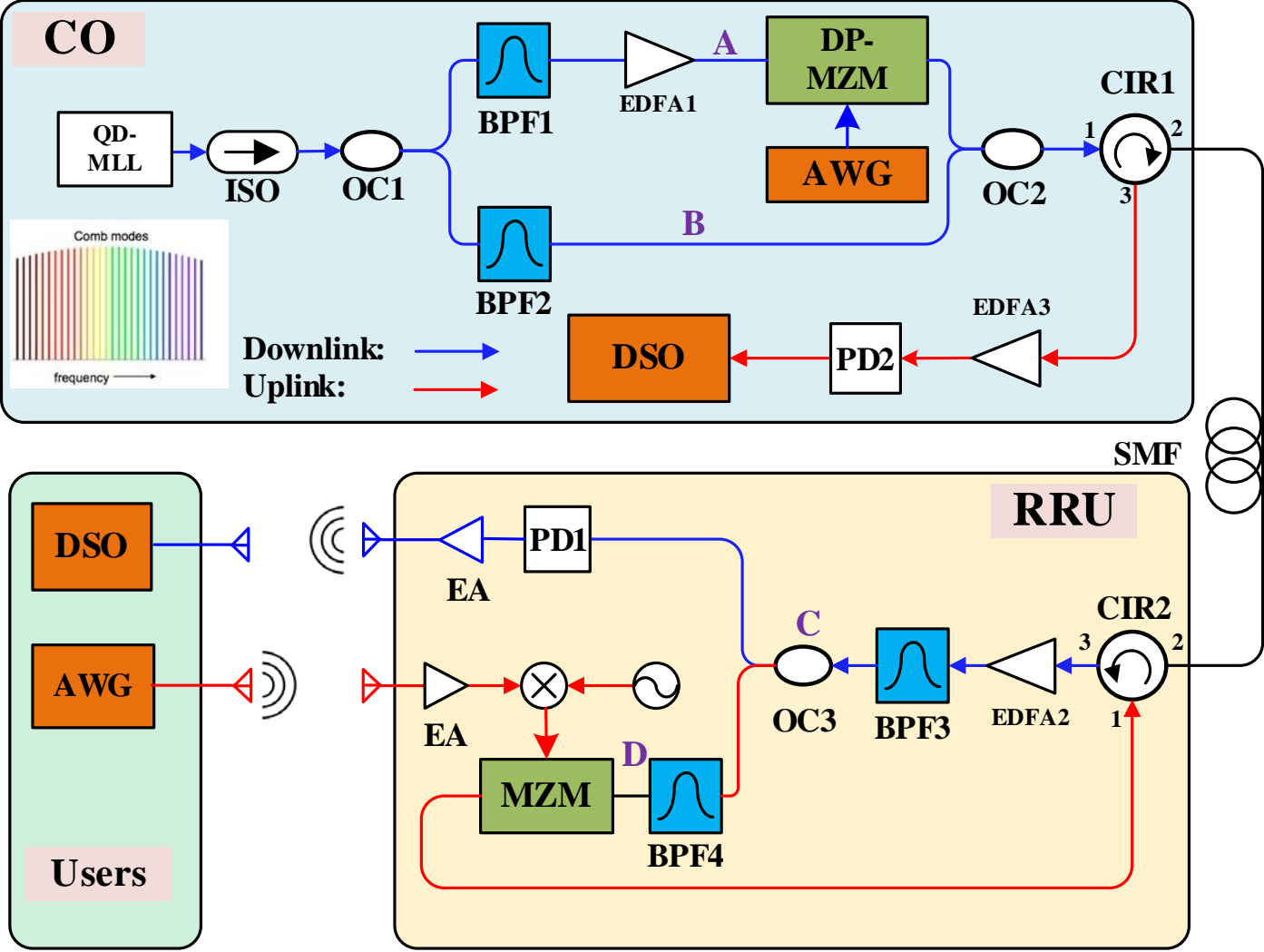

**Distance: 10 km SMF + 2 m wireless**  
**RF frequency: 25.08 + 3 GHz**  
**Data rate: 1 Gbaud/s**



# Experimental results - BER

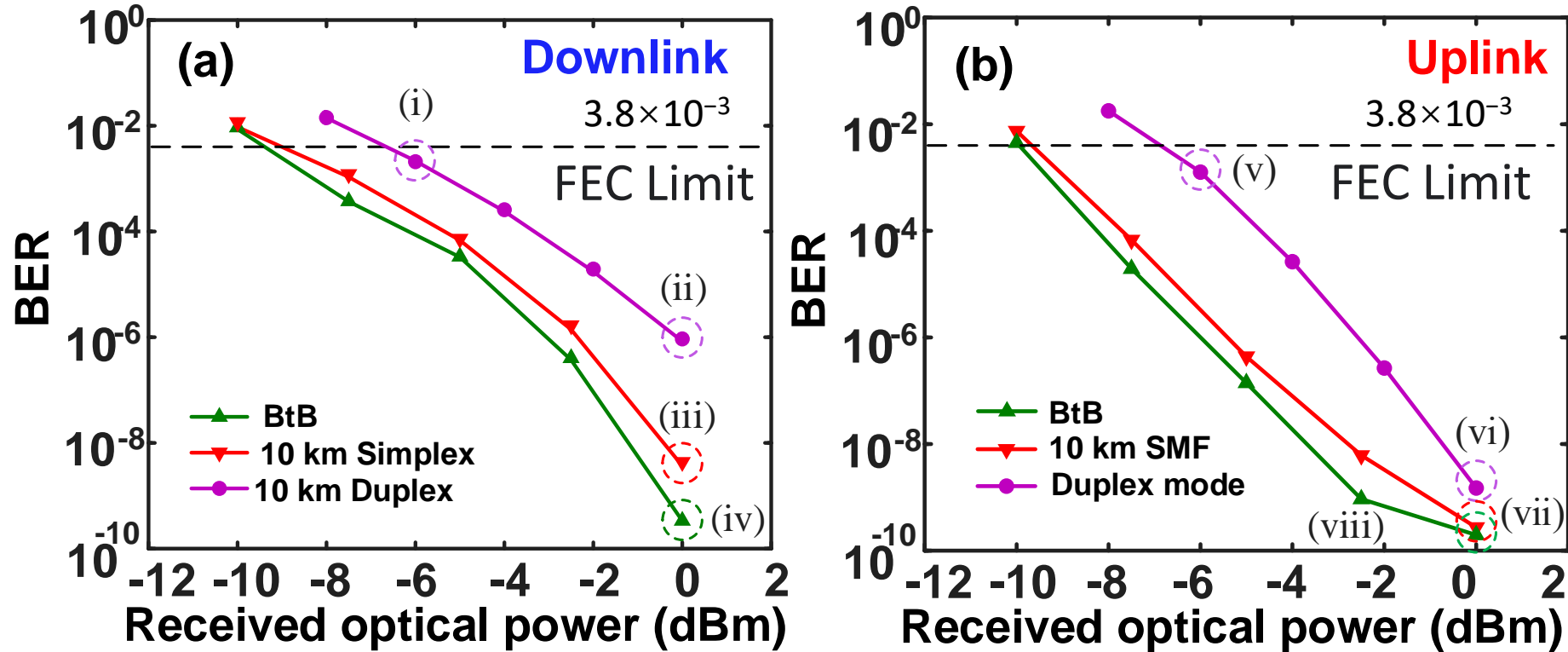

(a) BERs versus the received optical power for downlink transmission, blue: back-to-back, red: 10 km SMF in the simplex mode, and pink: 10 km SMF in the duplex mode. (b) BERs versus the received optical power for uplink transmission, blue: back-to-back, Red: 10 km SMF in the simplex mode, and ink 10 km SMF in the duplex mode.

# Experimental results

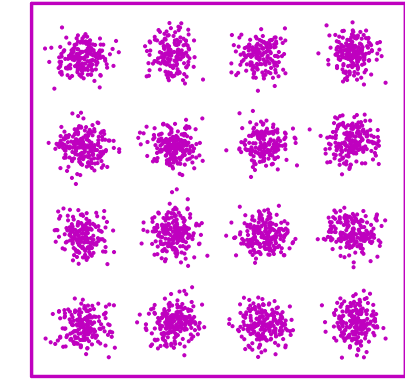

(i) EVM=16.66%

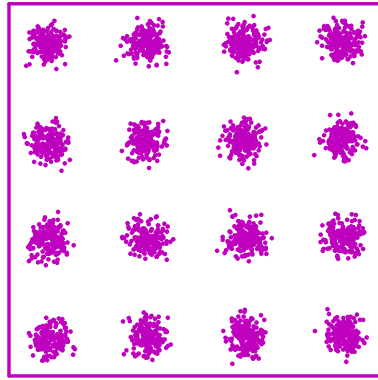

(ii) EVM=9.48%

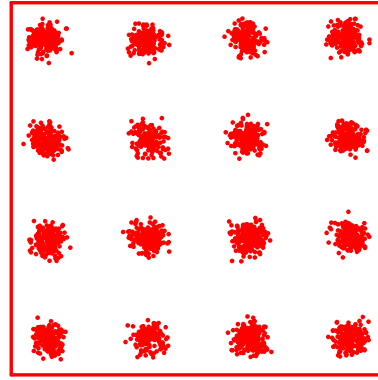

(iii) EVM=8.20%

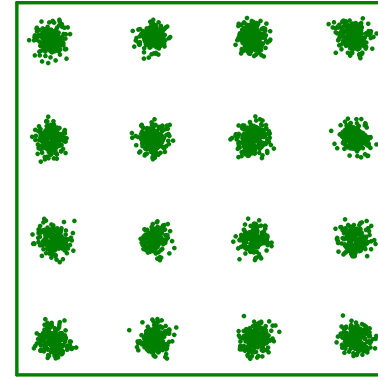

(iv) EVM=7.85%

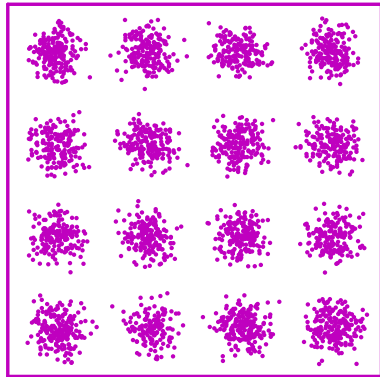

(v) EVM= 15.25%

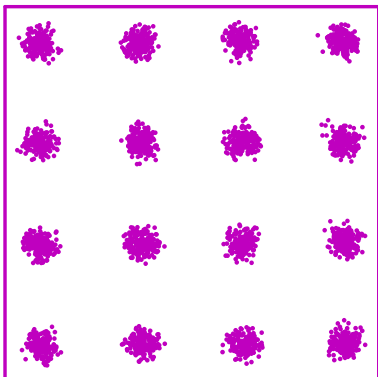

(vi) EVM= 7.57%

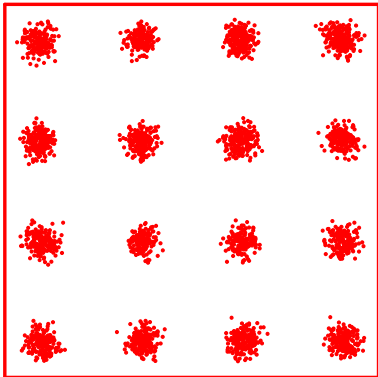

(vii) EVM= 7.26%

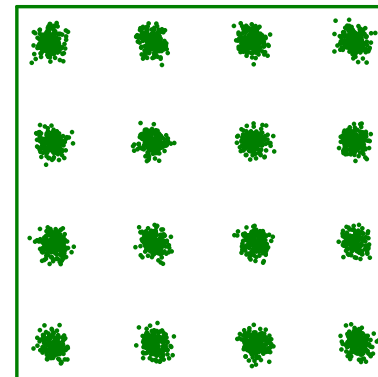

(viii) EVM= 7.23%

Constellation diagrams for the downlink and uplink transmission

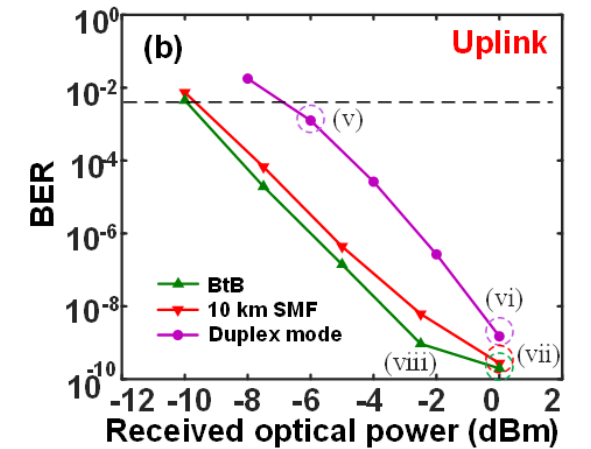
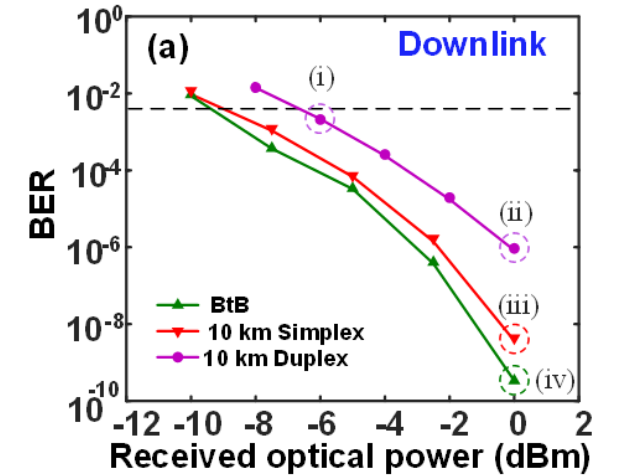

# MIMO transmission

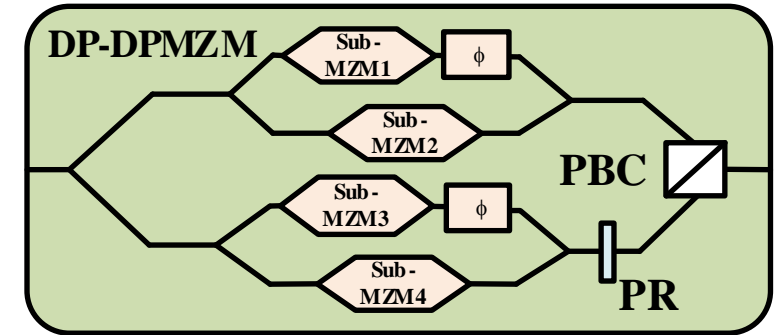
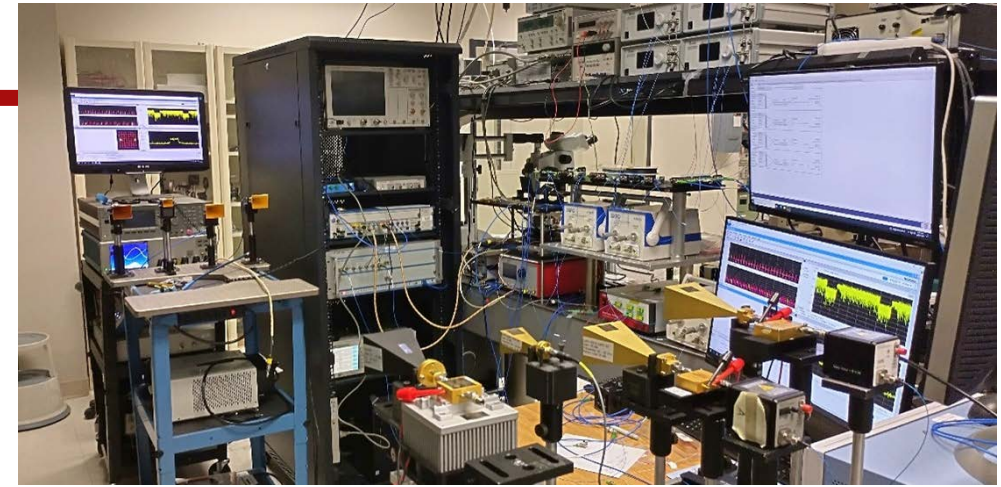
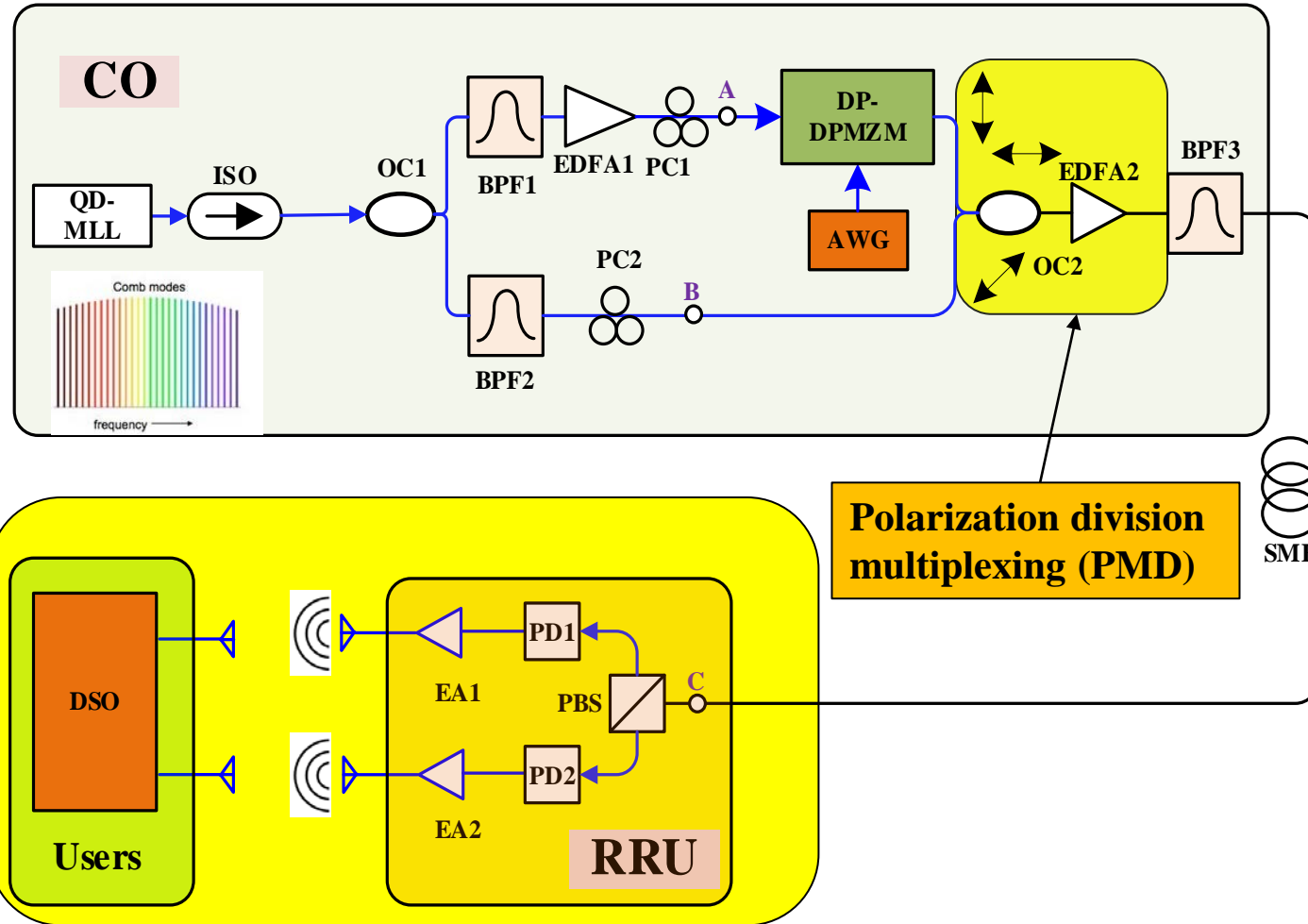

**Distance: 50 km SMF+ 2 m wireless**  
**RF frequency: 28.36 GHz**  
**Data rate: 4x2 Gbaud/s (32 Gbps)**

Schematic of the MMWoF-wireless-2×2 MIMO link using a QD-MLL.

# MIMO transmission

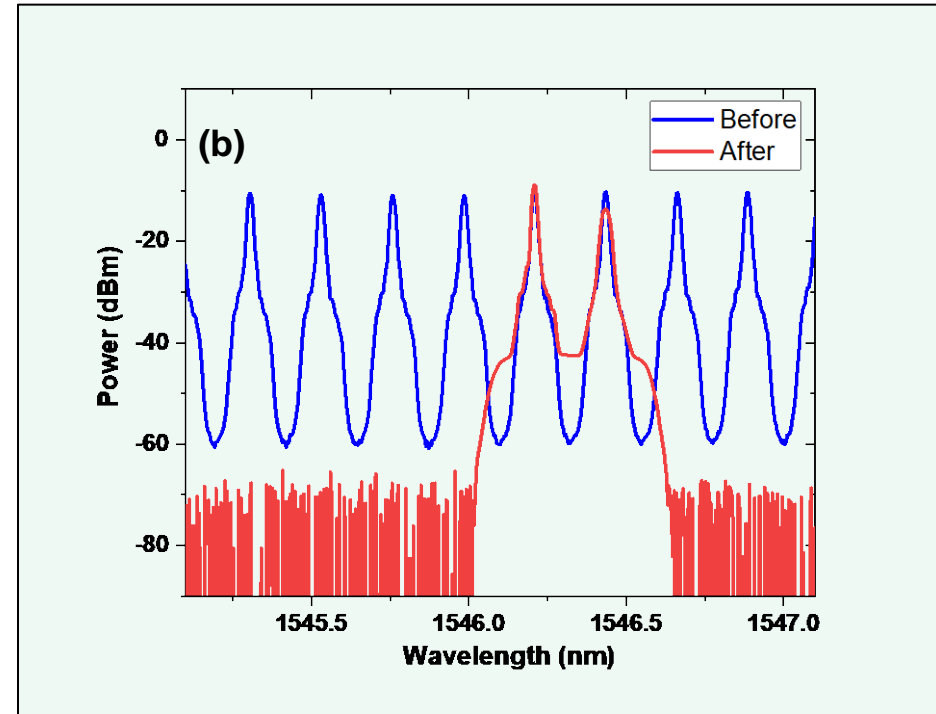
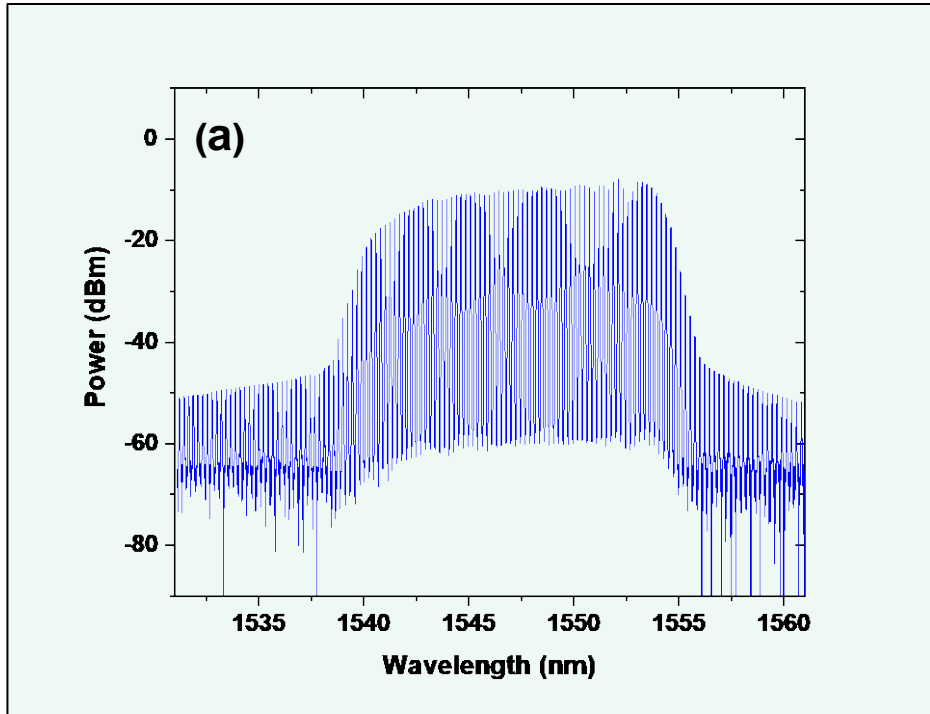

Measured optical spectrum of the QD-MLL (6-dB bandwidth of 12.1 nm with 54 comb lines; (b) filtered two comb lines with a frequency spacing of 28.36 GHz.

# MIMO transmission

28.36 GHz

28.36 GHz

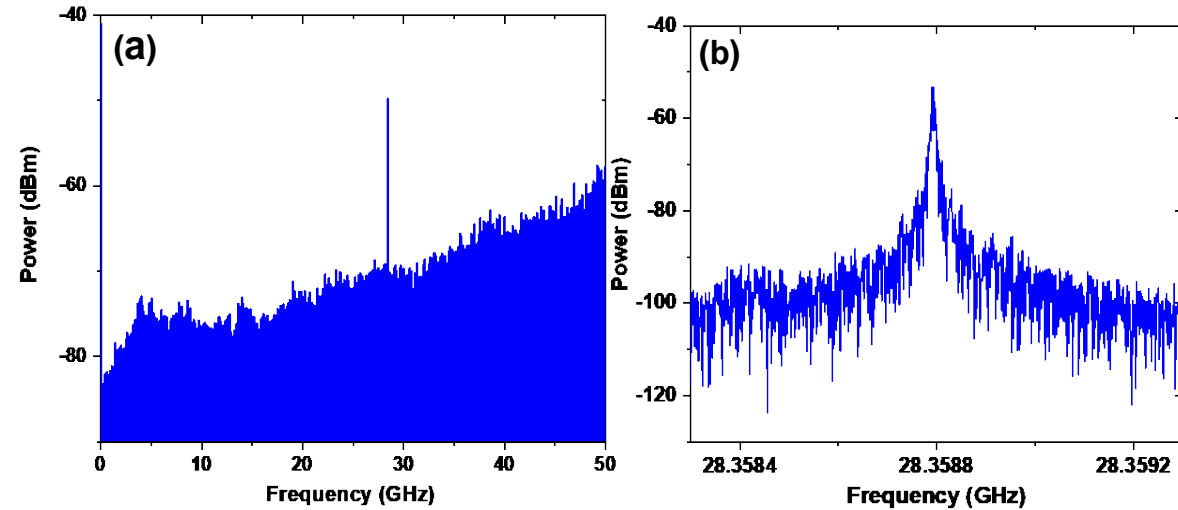

(a) The electrical spectrum of a heterodyning beat signal between two adjacent comb lines at 28.36 GHz and (b) the zoom-in view.

16 QAM at  
28.36 GHz

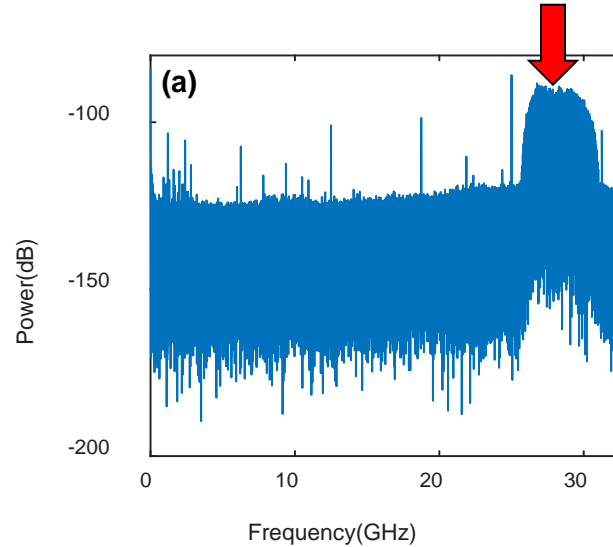

16 QAM at  
28.36 GHz

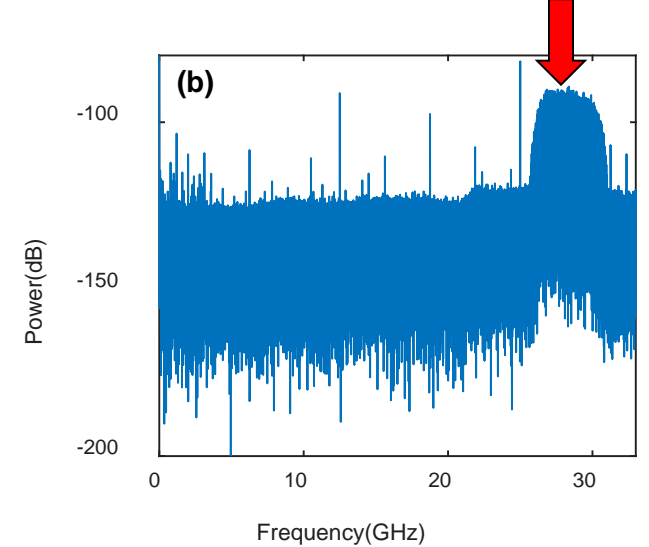

The electrical spectra of the received signals from the two receiving antennas. As can be seen, 16QAM signals at 28.36 GHz are generated.

# MIMO transmission- Algorithm

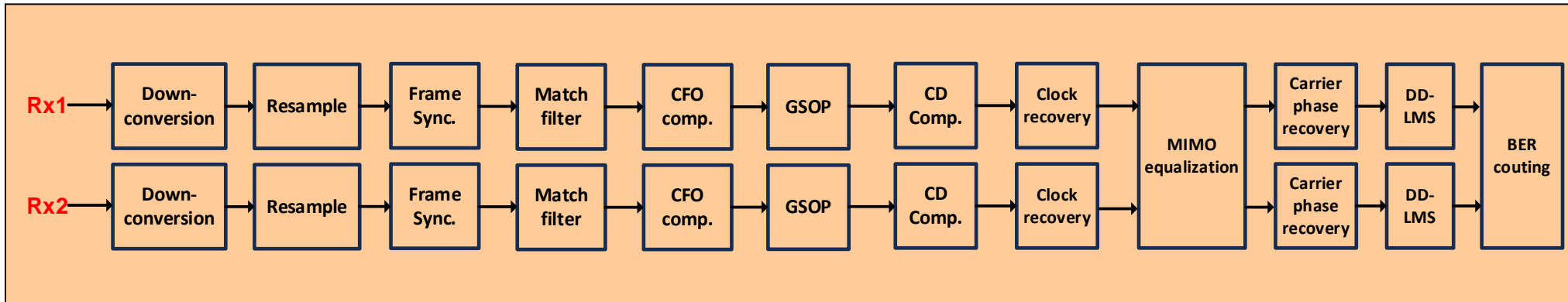

The DSP routine at the MIMO receiver includes

- Down-conversion
- Re-sampling
- Frame synchronization
- Matched filtering
- Carrier frequency offset (CFO) compensation
- Gram-Schmidt orthogonalization procedure (GSOP)
- Chromatic-dispersion (CD) compensation
- Clock recovery, MIMO equalization based constant modulus algorithm (CMA)
- Carrier phase recovery based on blind phase search (BPS) algorithm
- Decision-directed least mean square (DD-LMS) algorithm
- BER counting



# MIMO transmission – Experimental results

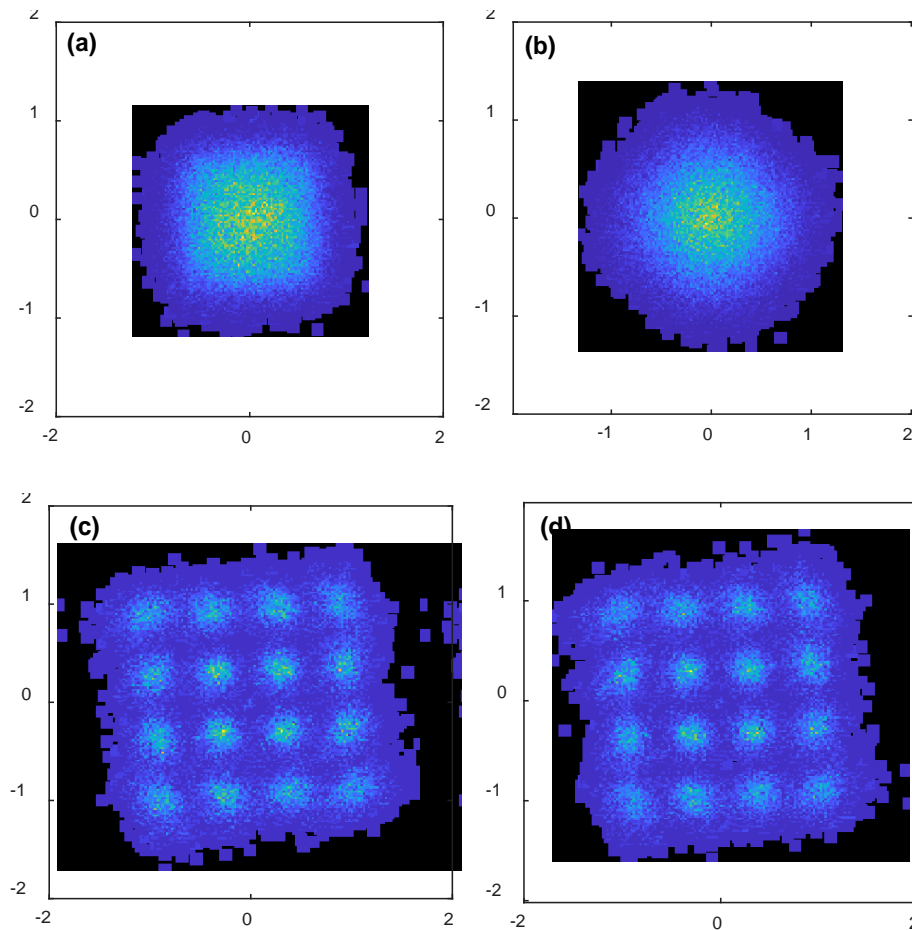

(a) and (b) constellation diagrams before MIMO equalization, (c) and (d) constellation diagrams after MIMO equalization.

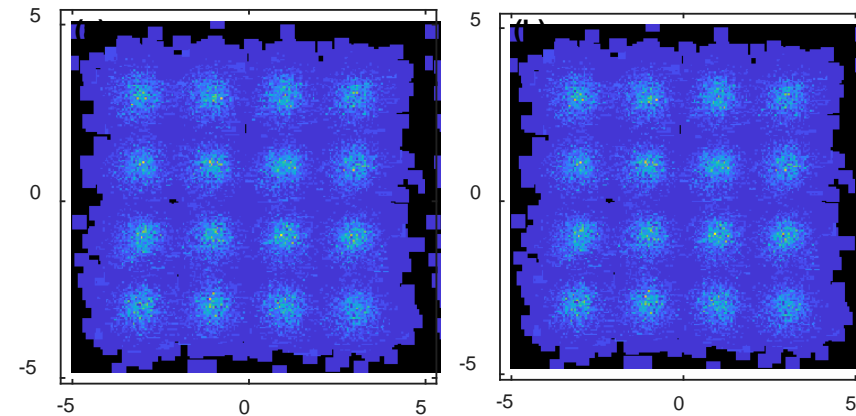

Constellation diagrams after carrier phase recovery. The measured EVM: (a) 17.28%, (b) 17.42%.

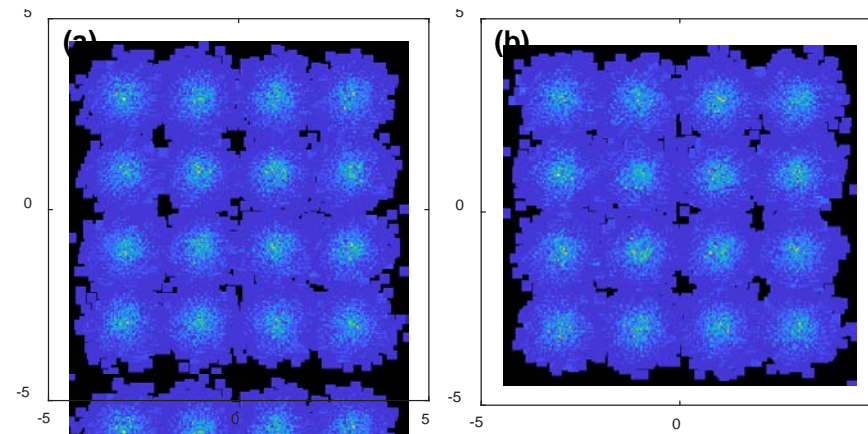

Constellation diagrams after Decision-directed least mean square (DD-LMS). The measured EVM: (a) 15.59%, (b) 15.69%.

# Phase noise compensation

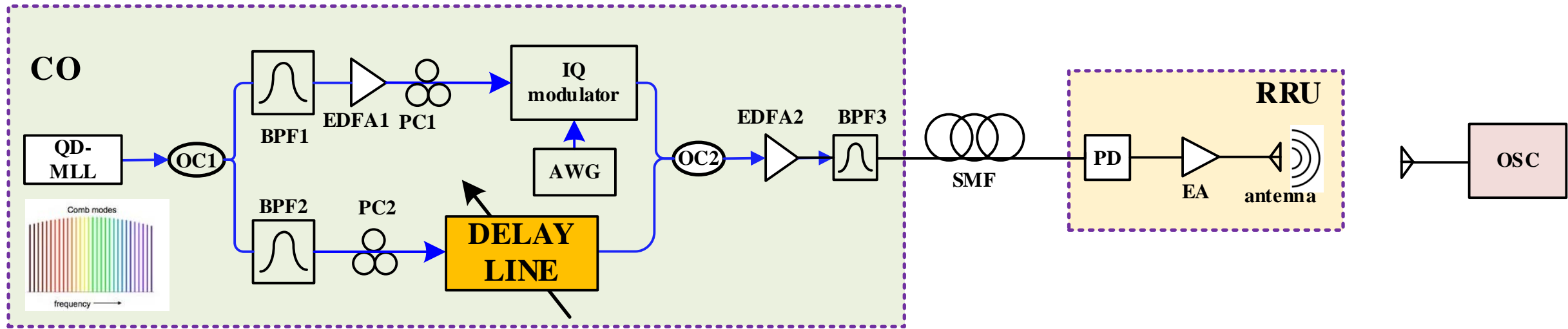

- If the **time delay** between the two comb lines is not matched, the phase noise of the comb lines would be transferred to the generated microwave signal to generate a **time-delay induced phase noise**.
- The time-delay induced phase noise can be eliminated using analog time matching
- **Differential phase noise** between the two comb lines is generated due to the passive mode locking jitter
- Through phase noise compensation, transmission performance is increased for a 10 Gb/s OFDM signal at 25 GHz over a 10 km single-mode fiber (SMF) and a 2-m wireless link

# Phase noise compensation

Mathematically, two comb lines can be expressed

$$E_1(t) = e^{j2\pi f_1 t} e^{j\phi(t)}$$

$$E_2(t) = e^{j2\pi f_2 t} e^{j\phi(t)} e^{j\psi(t)}$$

- $f_{1,2}$  are the optical frequencies
- $\phi(t)$  is the **phase noise** (due to the finite linewidth) which can be cancelled if the time delay difference is zero
- $\psi(t)$  is the **differential phase noise** between the two comb lines due to the passive mode locking jitter

# Phase noise compensation

$$E_c(t) = E_1(t) + E_2(t + \tau_d)$$

where  $\tau_d$  is the time delay between the two comb lines. The combined signal is sent to a RRU to beat at a PD to generate a microwave signal, with the photocurrent given by

$$I(t) \propto |E_c(t)|^2 \propto \cos(2\pi f_0 t + \Delta\phi(\tau_d) + \psi(t + \tau_d) + \omega_2 \tau_d)$$

where  $f_0 = f_2 - f_1$  is the microwave frequency, and  $\Delta\phi(\tau_d) = \phi(t + \tau_d) - \phi(t)$ .

As can be seen the **time-delay-induced phase noise**  $\Delta\phi(\tau_d)$  and the **differential phase noise**  $\psi(t + \tau_d)$  between the two comb lines

# Phase noise compensation

---

- For the transmission of an OFDM signal: the phase noise has two effects on an OFDM signal: a **common phase error (CPE)** that is common to all carriers, and a **time varying frequency dependent error** which generates **inter-carrier interference (ICI)**
- CPE can be solved by estimating the mean phase rotation of each symbol from dedicated pilot subcarriers and rotating the received symbol back
- RF-pilot (RFP) phase compensation algorithm can be used to compensate both CPE and ICI

# Phase noise compensation

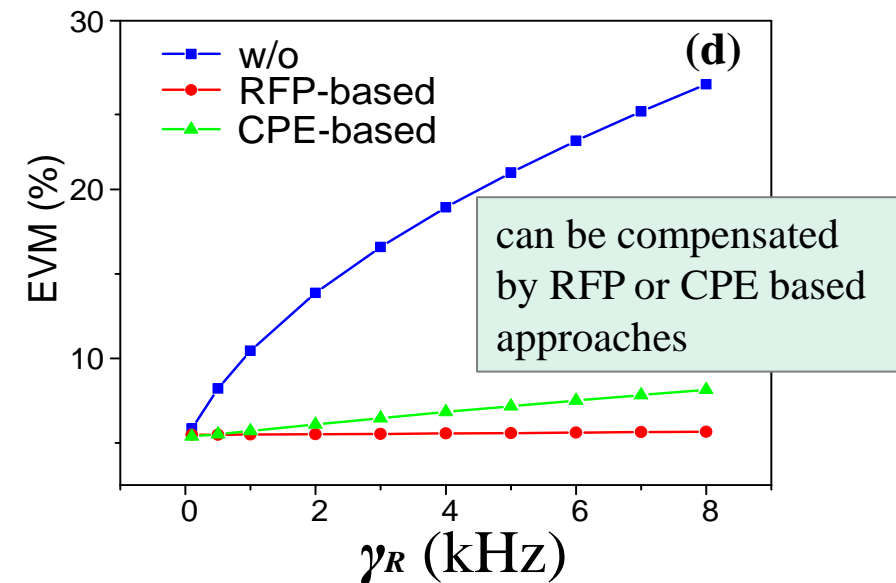
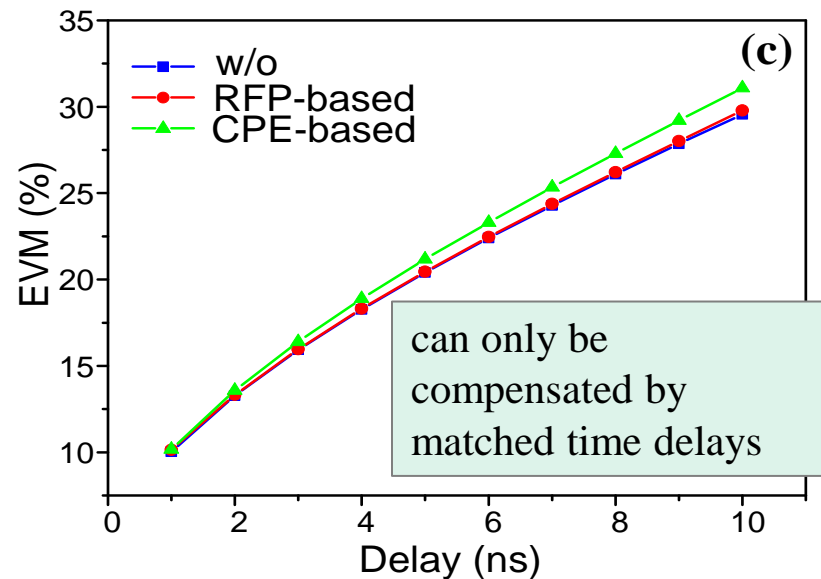
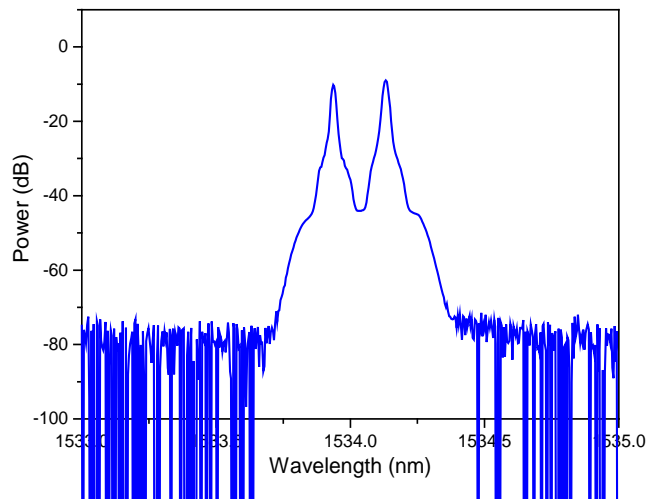
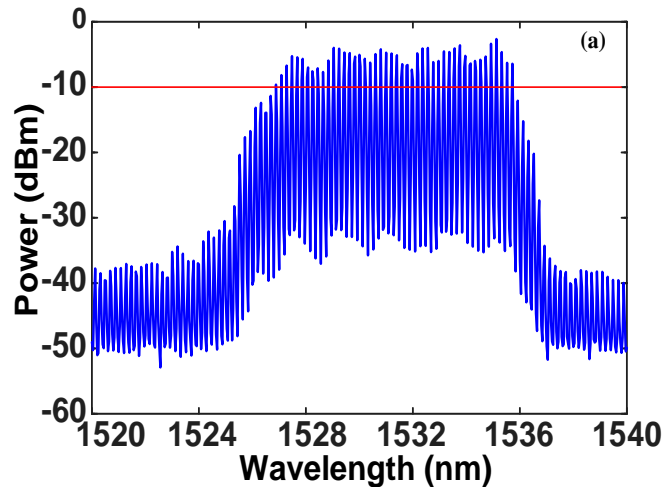

(a) The optical spectrum of the QD-MLL. (b) The optical spectrum of the two selected comb lines. Simulated EVM versus (c) time delay ( $\gamma_R = 0$  differential phase noise is zero,  $\gamma_O = 4.4$  MHz) (time delay phase noise cannot be compensated by both algorithms, but it can only be compensated by matched time delays) and (d) differential phase noise  $\gamma_R$  ( $\gamma_O = 0$ , time delay phase noise is zero).



# Phase noise compensation – Experimental results

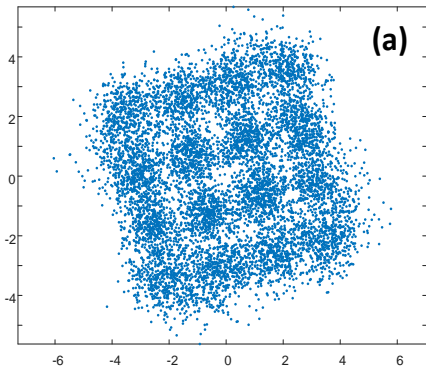

Not matched time delay: EVM=41.05%

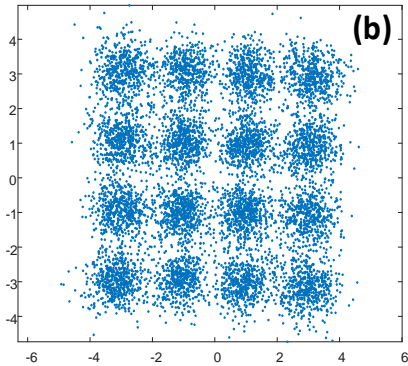

Not matched time delay, RFP, EVM=20.44%

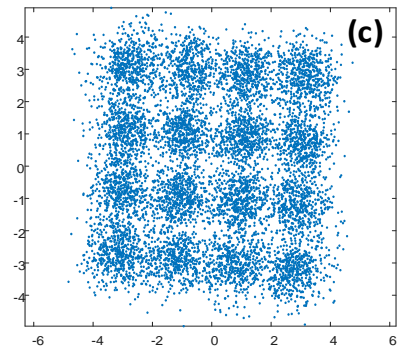

Not matched time delay, CPE, EVM=24.29%

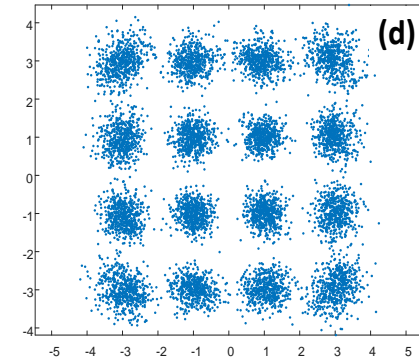

Matched time delay: EVM=14.40%

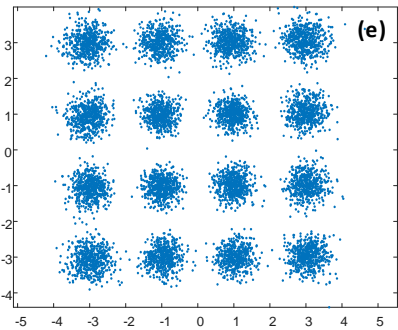

Matched time delay + REP: EVM=12.57%

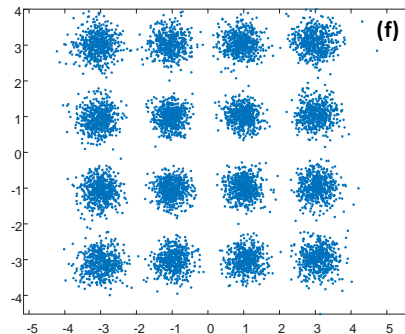

Matched time delay + CPE: EVM=12.67%

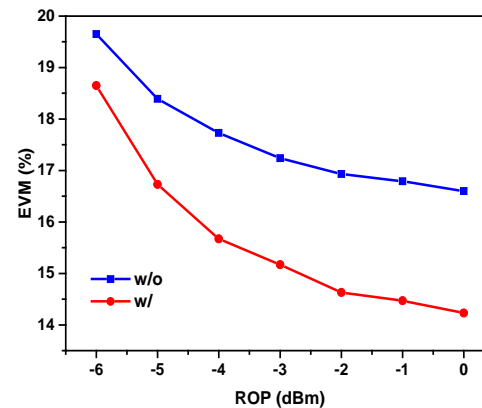

EVM with and without CPE versus ROP

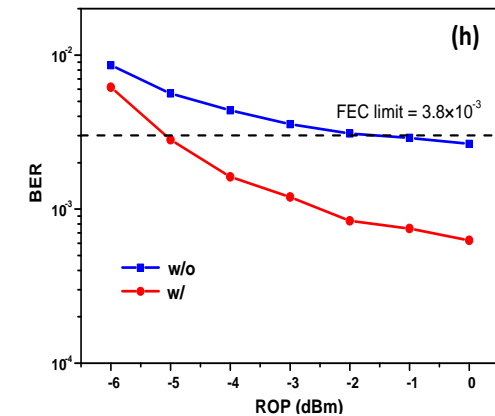

BER with and without CPE versus ROP

# Outline

---

- Introduction
- A duplex RoF link
  - Quantum-dash mode-locked laser
  - Duplex transmission experiment
  - MIMO transmission
  - Phase noise compensation
- **Photonic integrated solution**
- RoF links for integrated sensing and communications (ISAC)
- Conclusion

# Photonic integrated solution - Architecture

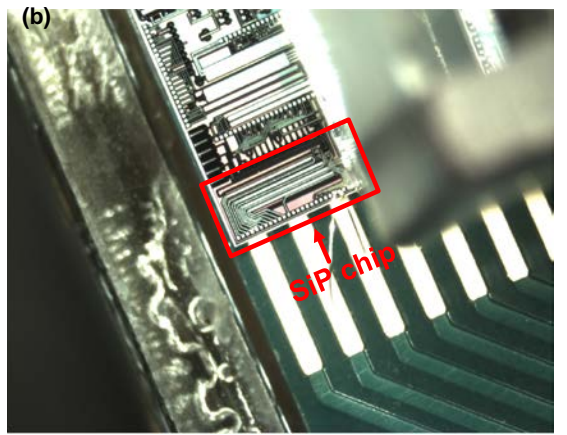
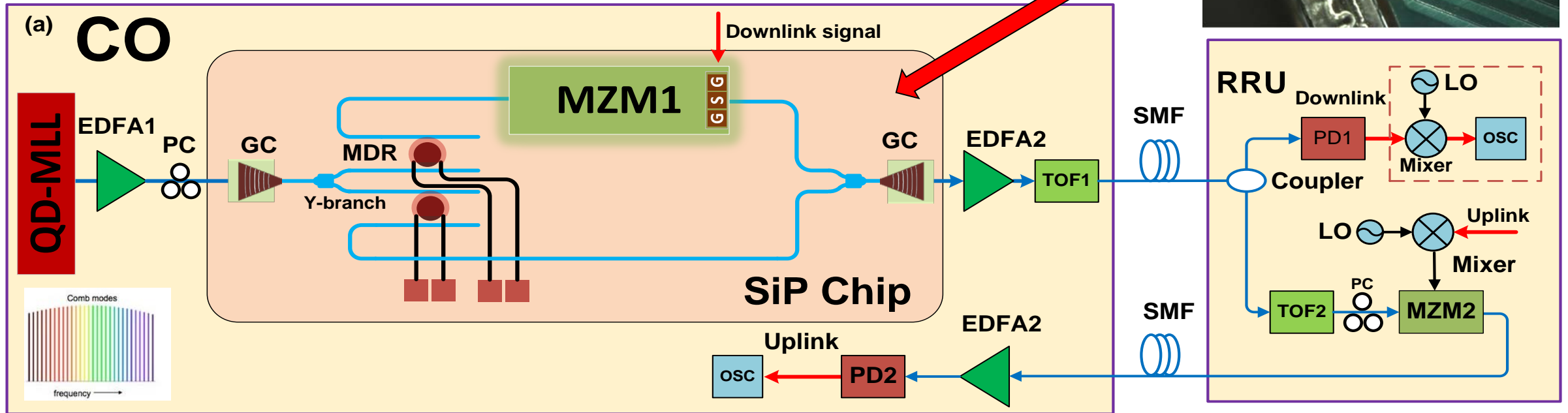

(a) Schematic diagram of a duplex MMWoF link based on a SiP integrated transmitter incorporating a QD-MLL. (b) A picture of the SiP chip.

**Distance: 10 km SMF**  
**RF frequency: 42.3 GHz**  
**Data rate: 200 MSym/s**

# Photonic integrated solution

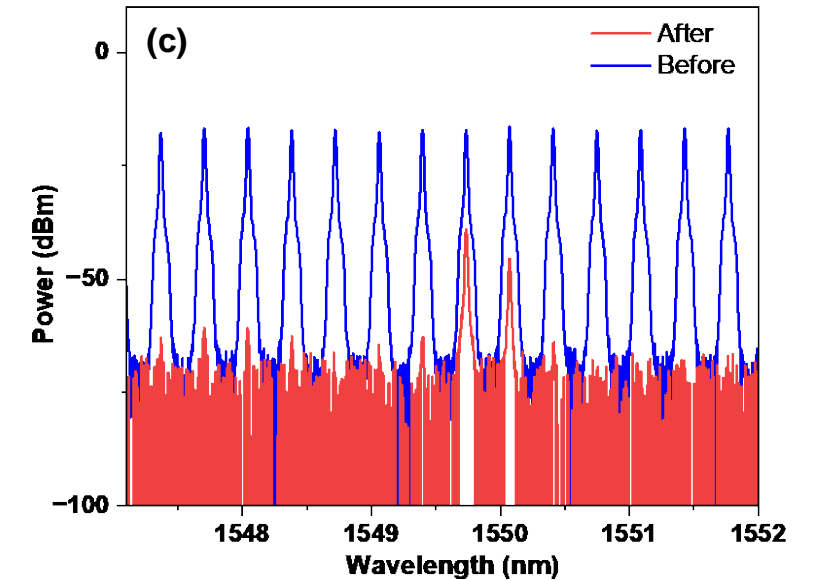
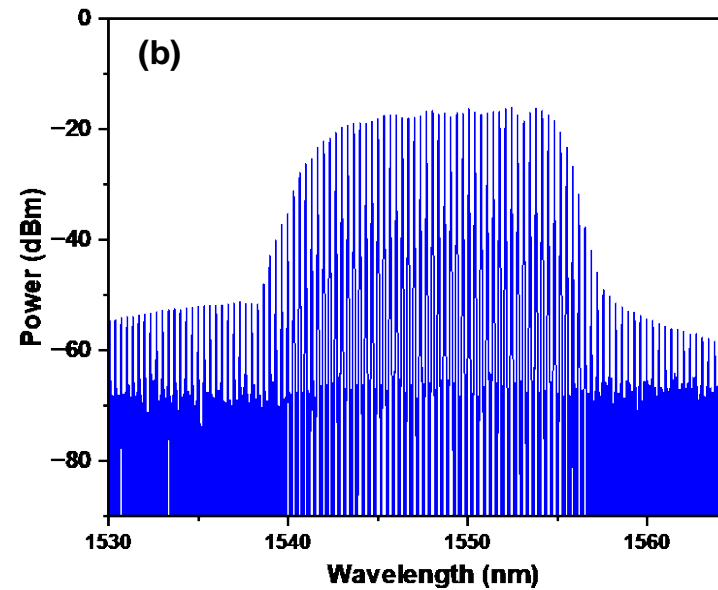
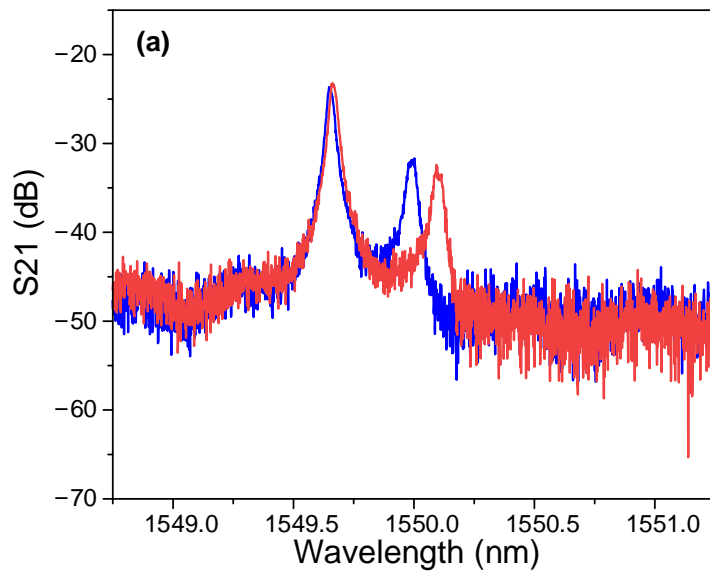
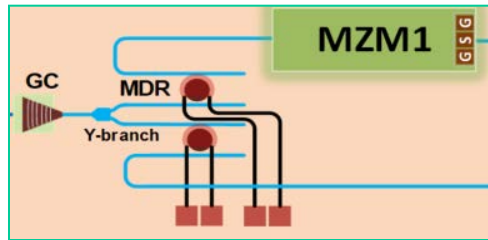
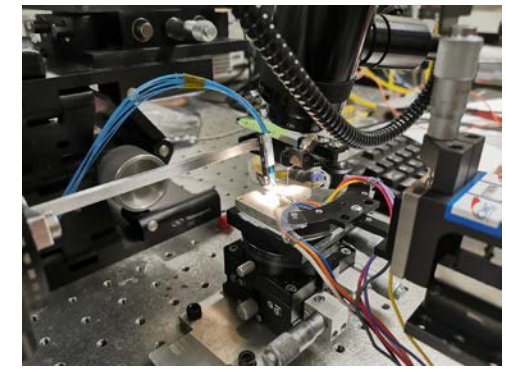

(a) Measured magnitude response of the SiP chip, (b) spectrum of the optical comb generated by the QD-MLL (comb spacing **42.3 GHz**), (c) the optical spectrum before (blue) and after (red) the SiP chip.

# Photonic integrated solution - downlink

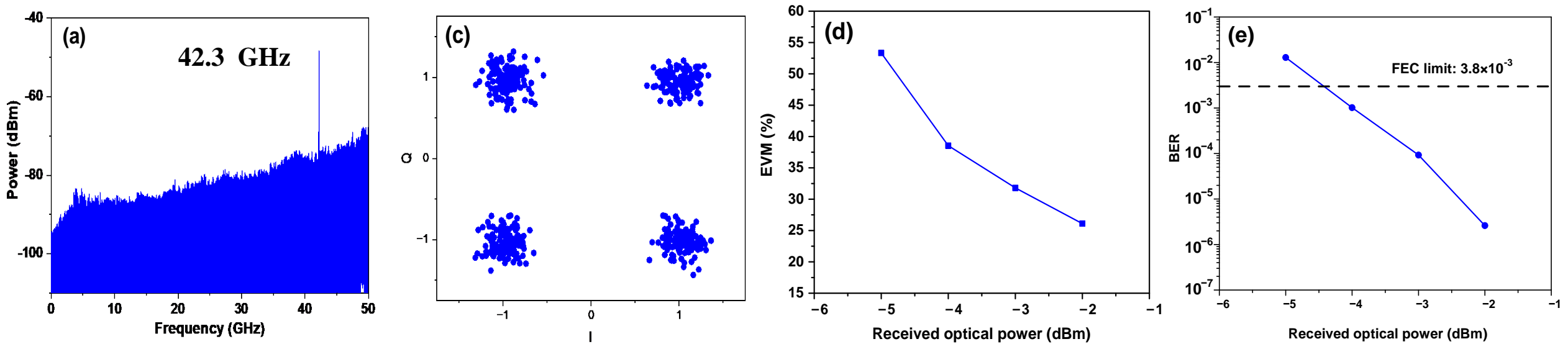

(a) Electrical spectrum of the generated MMW signal, (b) the constellation of the recovered QPSK signal, (c) measured EVMs at different received optical power levels, (d) estimated BERs.

**Distance: 10 km SMF**  
**RF frequency: 42.3 GHz**  
**Data rate: 200 MSym/s**

# Photonic integrated solution - uplink

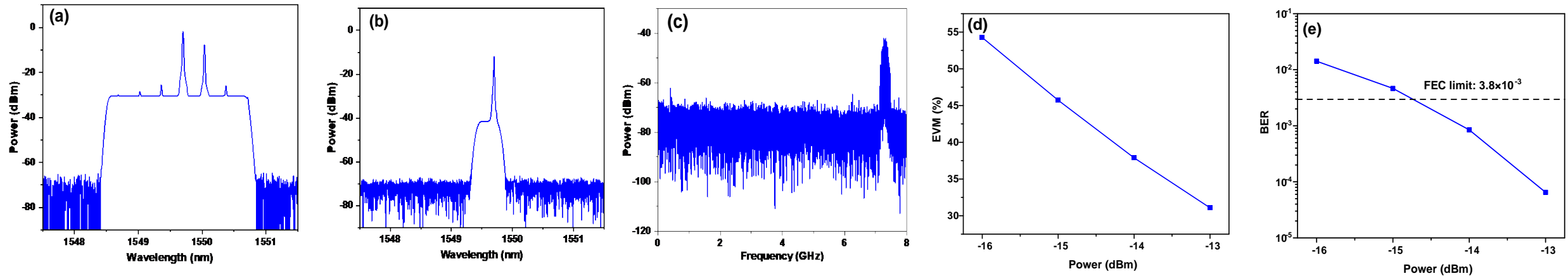

Measured optical signal (a) before and (b) after TOF2 at the RRU. (c) The electrical spectrum of the uplink signal at 7.3 GHz. (d) Measured EVMs and (e) estimated BERs at different received optical power levels for the uplink.

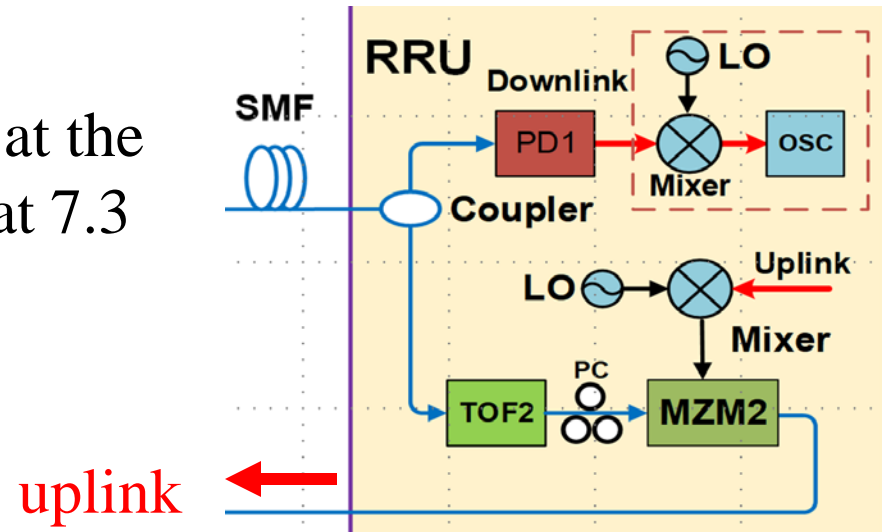



# Outline

---

- Introduction
- A duplex RoF link
  - Quantum-dash mode-locked laser
  - Duplex transmission experiment
  - MIMO transmission
  - Phase noise compensation
- Photonic integrated solution
- **RoF links for integrated sensing and communications (ISAC)**
- Conclusion

# RoF links for ISAC

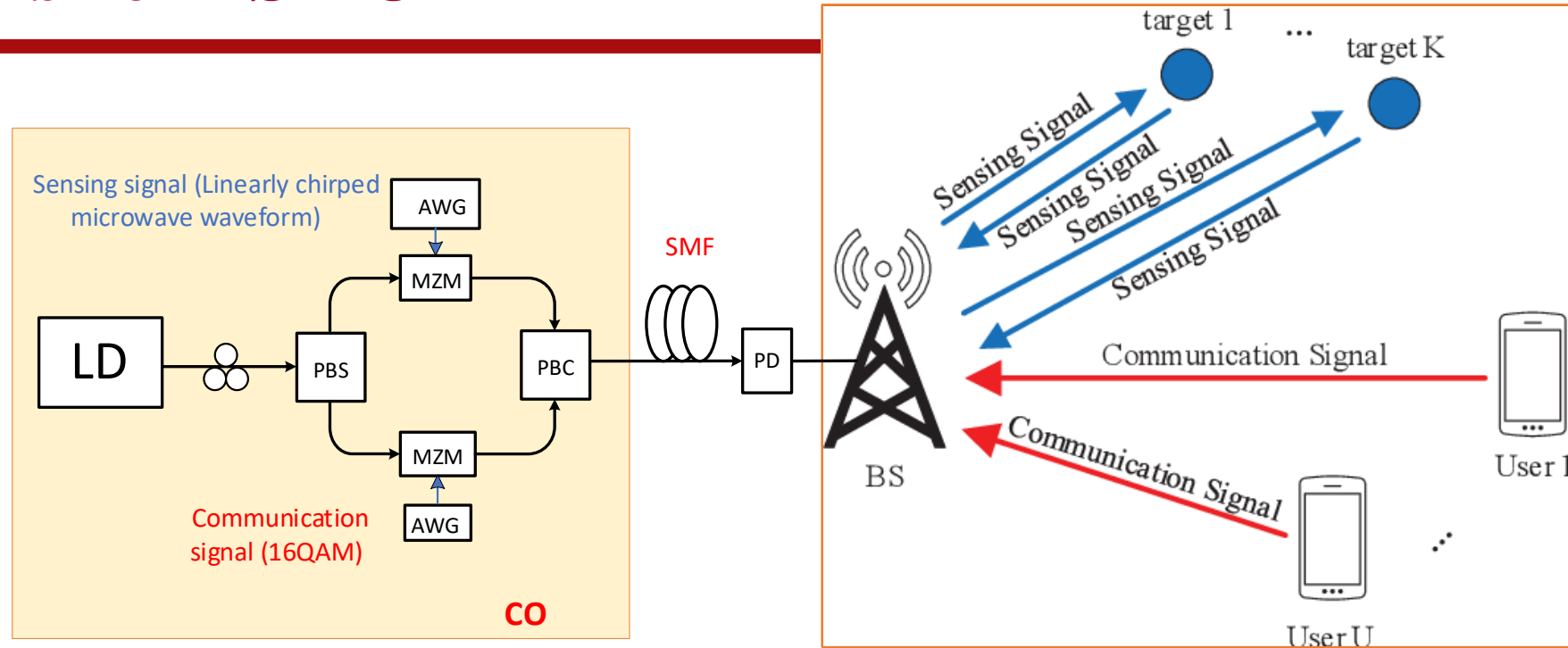

Joint radar and communication (JRC) can be implemented based on:

- 1) Time-division multiplexing (TDM)
- 2) Frequency division multiplexing (FDM)
- 3) Polarization division multiplexing, and
- 4) Co-time and co-frequency (CTCF)

# Integration of Sensing and Communication in a W-Band Fiber-Wireless Link Enabled by Electromagnetic Polarization Multiplexing

Mingzheng Lei, Min Zhu, Yuancheng Cai, Miaomiao Fang, Wei Luo, Jiao Zhang, Bingchang Hua, Yucong Zou, Xiang Liu, Weidong Tong, and Jianjun Yu, Fellow, IEEE, Fellow, Optica

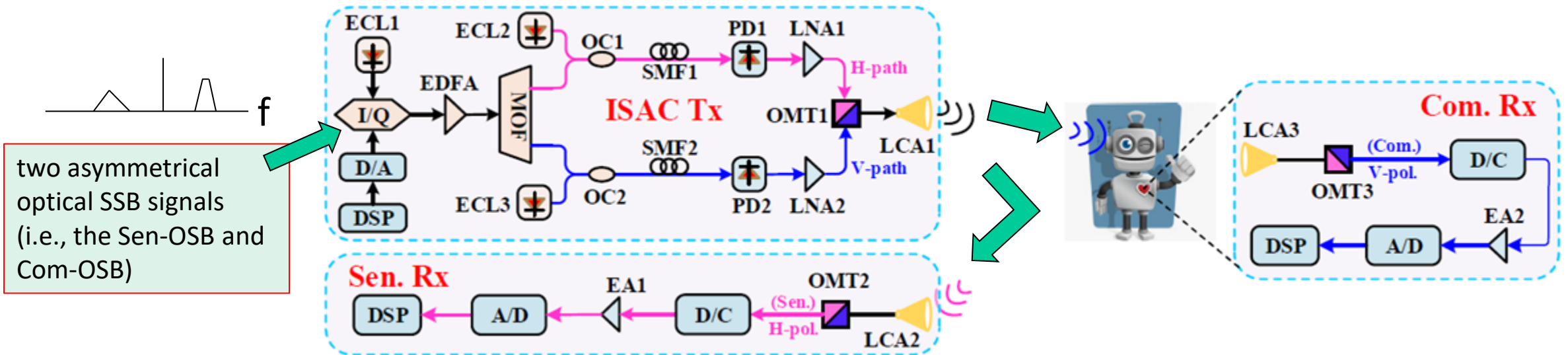
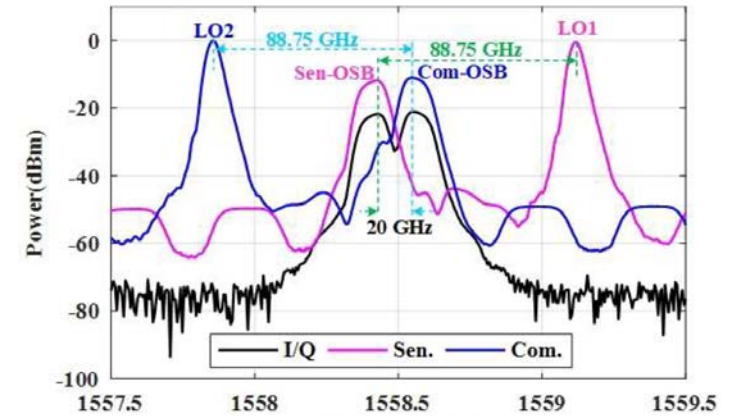

- A 23-GHz bandwidth linearly chirped microwave waveform (LCMW) and a 23-GBaud 16QAM signal were successfully generated and transmitted over a wireless distance of 10.8 m. MOF: multi-channel optical filter
- A spatial resolution of up to 15 mm and a data rate as high as 92 Gbit/s were achieved.

OMT: Orthomode Transducer

## Photonic super-resolution millimeter-wave joint radar-communication system using self-coherent detection

WENLIN BAI,<sup>1</sup> PEIXUAN LI,<sup>1,\*</sup> XIHUA ZOU,<sup>1,2</sup> NINGYUAN ZHONG,<sup>1</sup> WEI PAN,<sup>1</sup> LIANSHAN YAN,<sup>1</sup> AND BIN LUO<sup>1</sup>

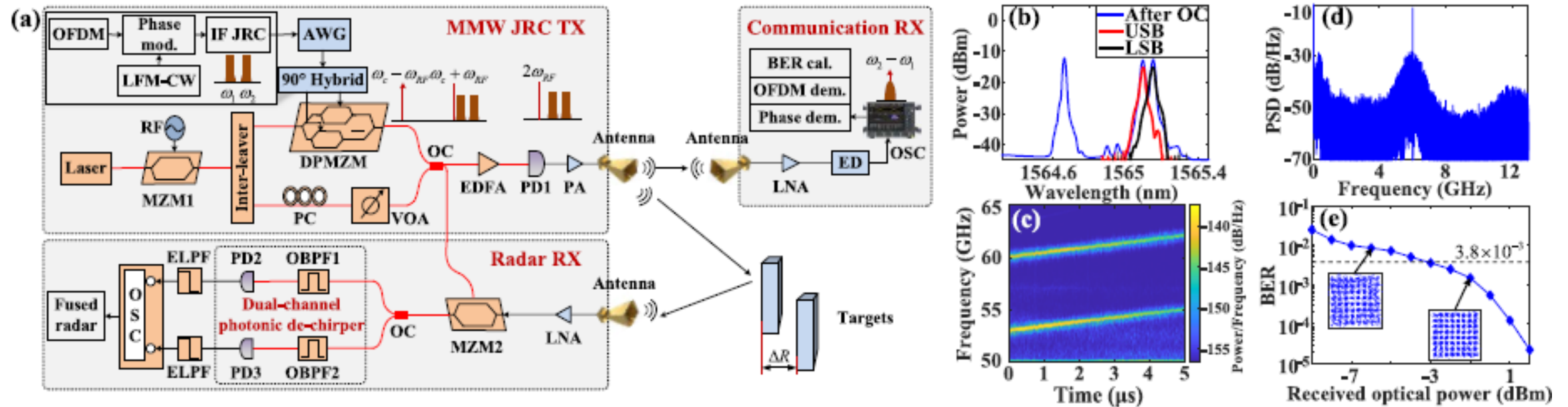

IF JRC signal (chirped + data)

$$s_{IF-JRC}(t) = A \{ \exp j[\omega_1 t + \pi k t^2 + 2\pi h m(t)] + \exp j[\omega_2 t + \pi k t^2 - 2\pi h m(t)] \},$$

$$E_{MZM1}(t) \propto E_1 J_1(\beta) \exp j\omega_c t \{ \exp(-j\omega_{RF} t) + \exp j\omega_{RF} t \},$$

$$E_{OC}(t) \propto E_1 J_1(\beta) \exp j[(\omega_c - \omega_{RF})t] + E_1 J_1(\beta) E_2 J_1(\gamma) \cdot \left\{ \begin{array}{l} \exp j[(\omega_c + \omega_{RF} + \omega_1)t + \pi k t^2 + 2\pi h m(t)] \\ + \exp j[(\omega_c + \omega_{RF} + \omega_2)t + \pi k t^2 - 2\pi h m(t)] \end{array} \right\},$$

chirped OFDM

$$i_{PD1}(t) \propto R \{ \cos[(2\omega_{RF} + \omega_1)t + \pi k t^2 + 2\pi h m(t)] + \cos[(2\omega_{RF} + \omega_2)t + \pi k t^2 - 2\pi h m(t)] \},$$

PD1 output, upper path

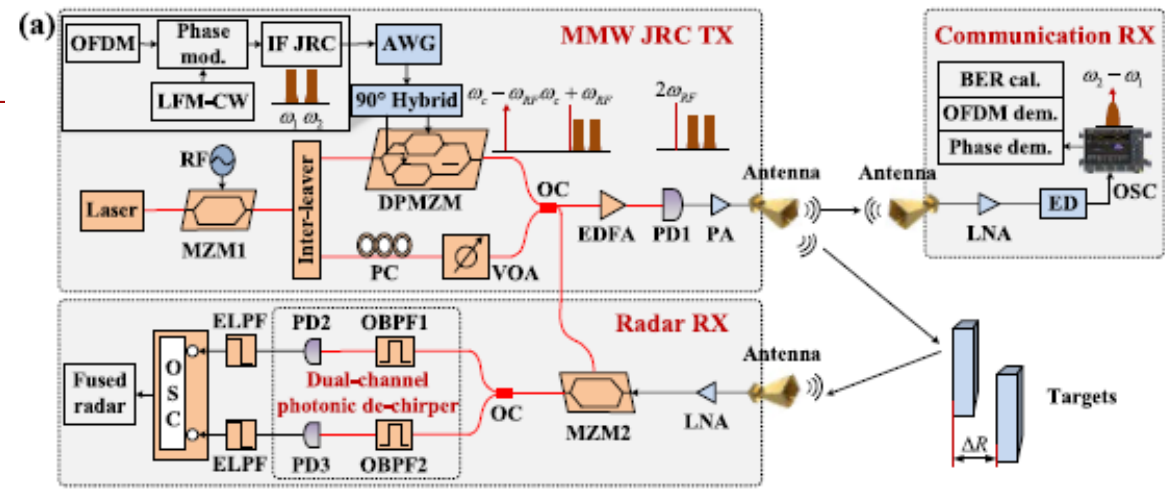

(1)

(2)

(3) ←

CS-SSB modulation, upper path

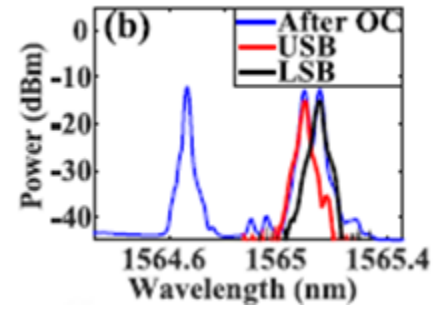

(4)

$$i_{ED}(t) \propto G \{ \cos[(\omega_2 - \omega_1)t + 4\pi h m(t)] \},$$

Communication RX



## Photonic super-resolution millimeter-wave joint radar-communication system using self-coherent detection

WENLIN BAI,<sup>1</sup> PEIXUAN LI,<sup>1,\*</sup> XIHUA ZOU,<sup>1,2</sup> NINGYUAN ZHONG,<sup>1</sup> WEI PAN,<sup>1</sup> LIANSHAN YAN,<sup>1</sup> AND BIN LUO<sup>1</sup>

$$E_{OBPF_i} \propto \left\{ \exp j[(\omega_c + \omega_{RF} + \omega_i + \pi kt)t \pm 2\pi hm(t)] + \exp j[(\omega_c + \omega_{RF} + \omega_i + \pi kt - 2\pi k\tau)t \pm 2\pi hm(t - \tau)] \right\}, \quad (6)$$

Received echo signal

$$i_{de-chirped_i}(t) \propto C_i \cos[2\pi k\tau t \pm 2\pi hm'(t)], \quad (7)$$

De-chirped signal

$$m'(t) = m(t) - m(t-t)$$

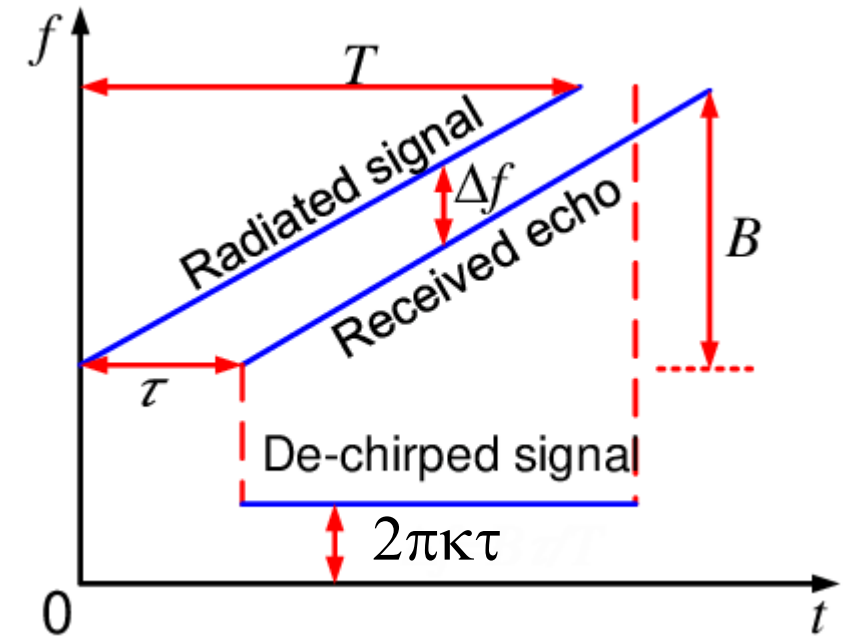



# Conclusion

---

1. **Increased bandwidth:** Optical fibers have a much higher bandwidth compared to traditional copper cables.
2. **Low loss:** Optical fibers have significantly lower transmission losses compared to copper cables, allowing signals to be transmitted over longer distances.
3. **Immunity to EMI:** providing a more reliable and interference-free communication channel.
4. **Light weight and compact:** Optical fibers are lightweight and can be more easily routed and installed compared to bulky copper cables.
5. **Secure communication:** Optical signals transmitted through fiber optic cables are difficult to tap or intercept.
6. **Various applications:** telecommunications, and sensing

# Acknowledgements

---

